

Shower Door
5/16" glass (8mm)

INSTALLATION GUIDE

CAUTION: To reduce the risk of breakage, keep corner protectors on glass while installing. Keep corner protectors for use in case future adjustments are needed. Consult your local plumbing codes prior to installation.

Recommended Clearance Heights for Installation:
74 inches (188 cm)

Recommended Width for Installation:
60-inch enclosure:
56 - 60 inches (142.2- 152.4 cm)

Recommended Width for Installation:
54-inch enclosure:
50 - 54 inches (127- 137.2 cm)

Recommended Width for Installation:
48-inch enclosure:
44 - 48 inches (111.8- 121.9 cm)

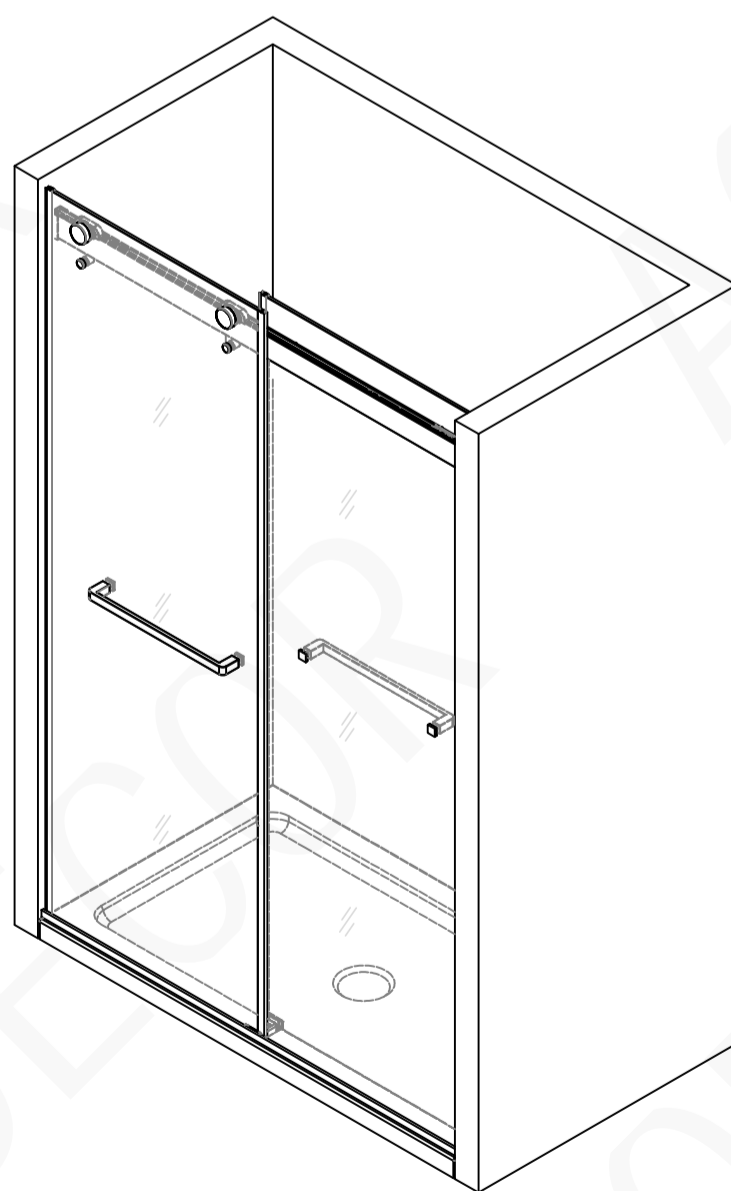

48X74-inch Enclosure

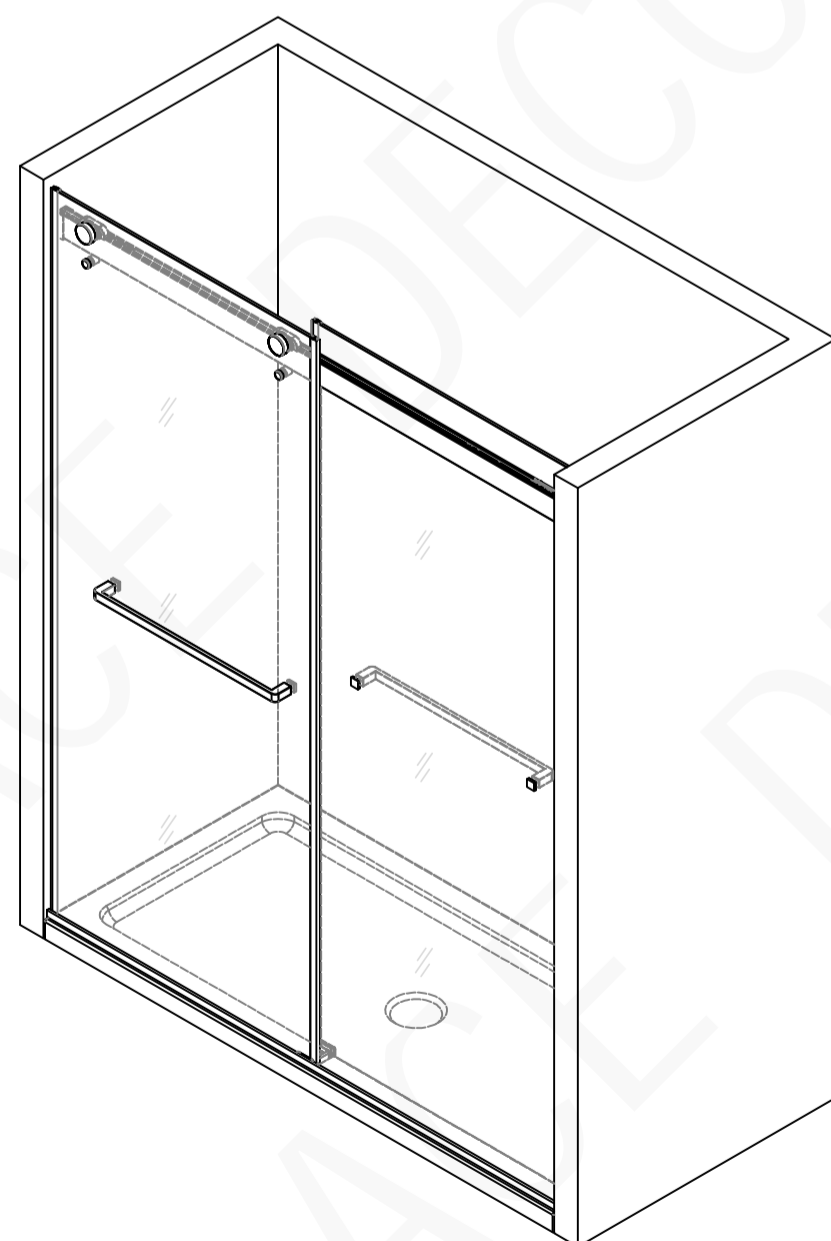

60X74-inch Enclosure

TOOLS REQUIRED

Drill Bits



Ø1/4" (6mm) & Ø1/8" (3mm) dia.
HSS

Screw Driver

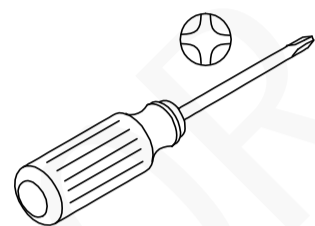

Drill

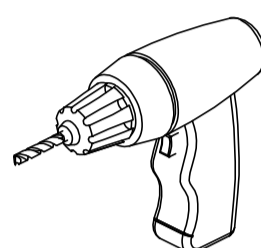

Level

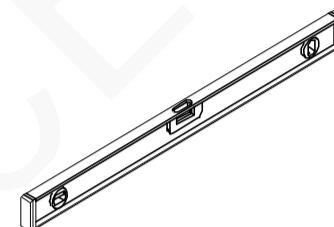

Silicone

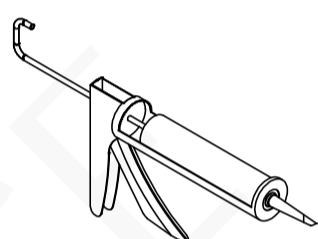

Measuring Tape

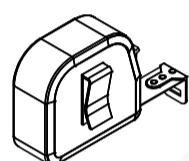

Soft Head Hammer

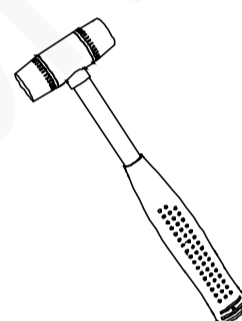

Pencil

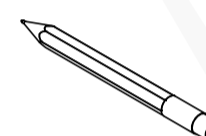

Knife

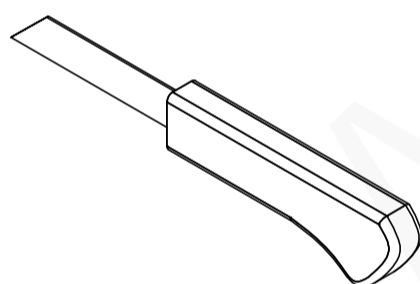

Sealant

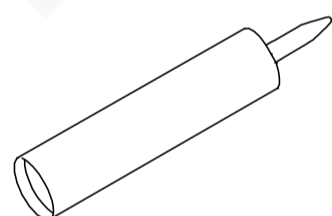

MASONRY DRILL BIT FOR TILE Ø6mm



Safety Glasses



Glove



Carpenter's Squarer

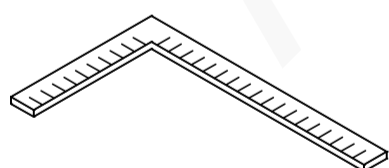

Masking or painter's tape

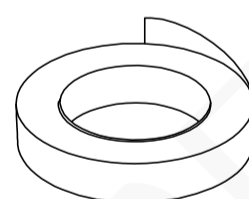

Hack Saw

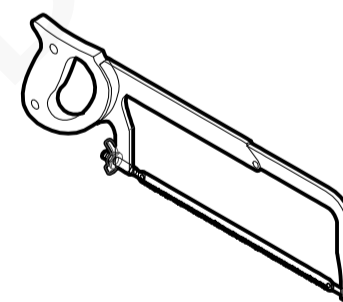

Metal File

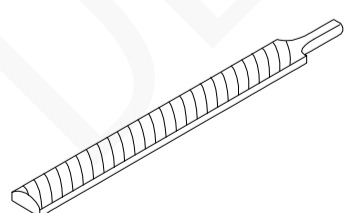

CAUTION: When cutting or drilling metal components or when handling glass, to reduce the risk of personal injury, protective eye wear, gloves, and closed-toe shoes are required.

SAFETY INFORMATION

CAUTION

Please carefully read the following important safety information before handling or installing this shower. There is a risk of serious injury while handling this product.

To minimize these risks, please note:

- Always wear safety glasses and gloves while handling.
- Always follow the installation instructions.
- Inspect glass for damage before installation.
- Extreme caution should be taken while handling the glass during installation as the tempered glass may shatter if in contact with a hard surface.
- Do not cut or modify the tempered glass as it will shatter if cut.
- Carefully remove product from packaging and keep packaging until installation is complete.
- Inspect all parts for damage or missing; if there is damage or part missing to the unit prior to installation, please contact customer service at the number provided in this guide.
- Cover the drain with tape to prevent the loss of small parts.
- The shower base and finished walls should be installed before beginning the shower door installation.
- During the installation, protect the shower floor with a drop cloth to avoid damage.
- This product should be installed by two people who are familiar with construction requirements. Professional installation is recommended!
- Keep this installation manual for future reference.

NOTE: Two people should perform this installation.

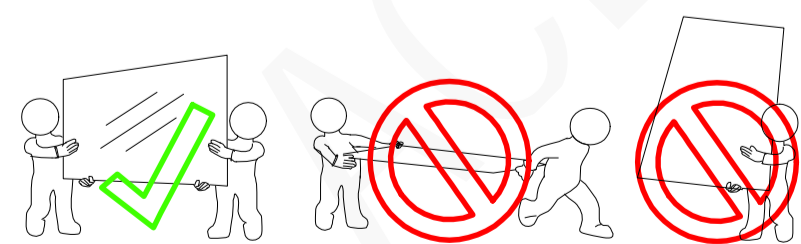

DOOR ASSEMBLY

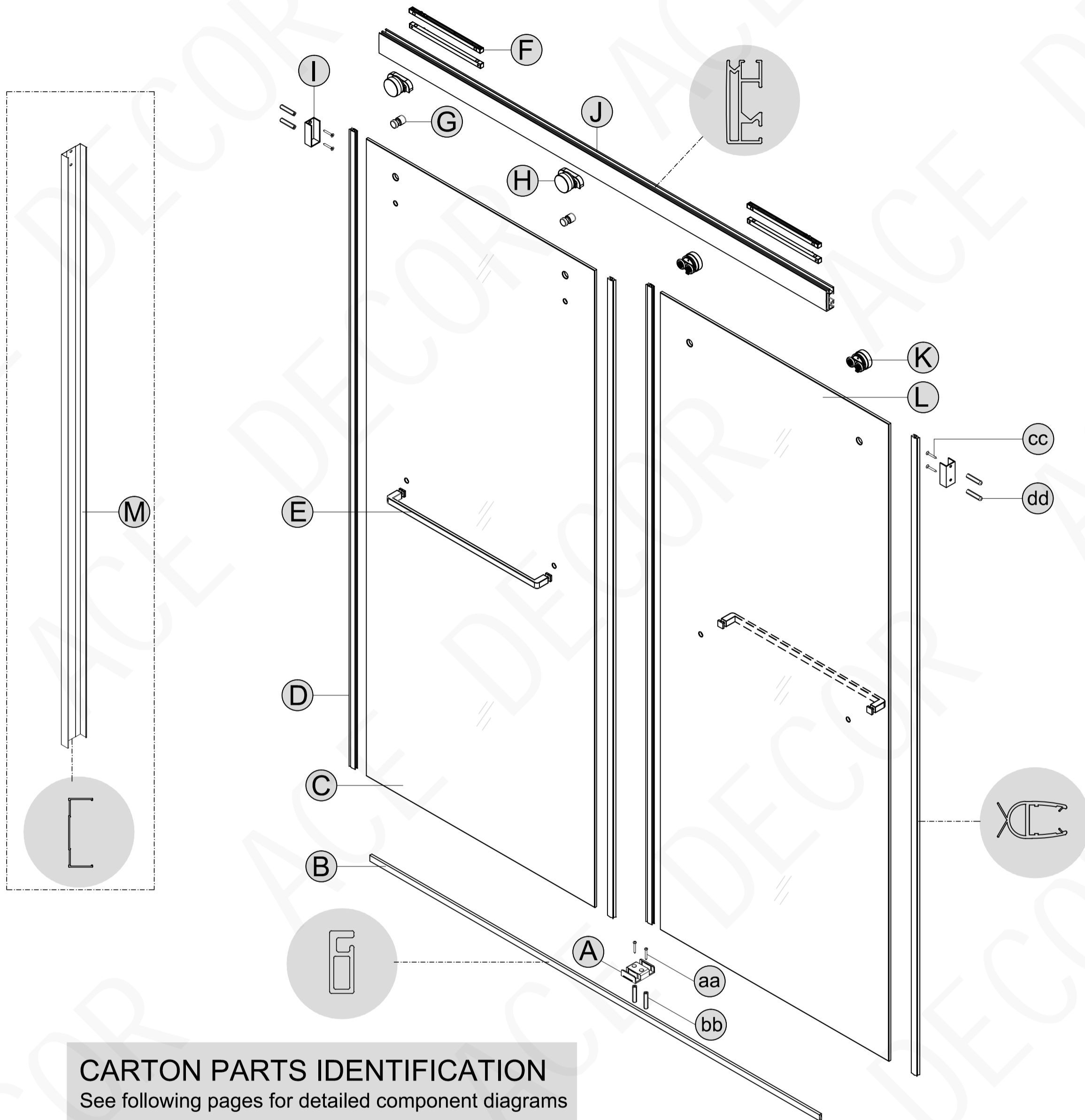

CARTON PARTS IDENTIFICATION

See following pages for detailed component diagrams

PART#	DESCRIPTION	QTY	PART#	DESCRIPTION	QTY
A	Bottom guide	1	H	Outside Roller	2
B	Bottom Rail	1	I	Wall Bracket Assembly	2
C	Outside Door panel	1	J	Upper Guide Rail	1
D	Anti-collision rubber strip	4	K	Inside Roller	2
E	Handle	2	L	Inside Door panel	1
F	Anti-Fluctuator	4	M	Templates	1
G	Anti-Jump Assembly	2			

CARTON PARTS IDENTIFICATION

See following pages for detailed component diagrams

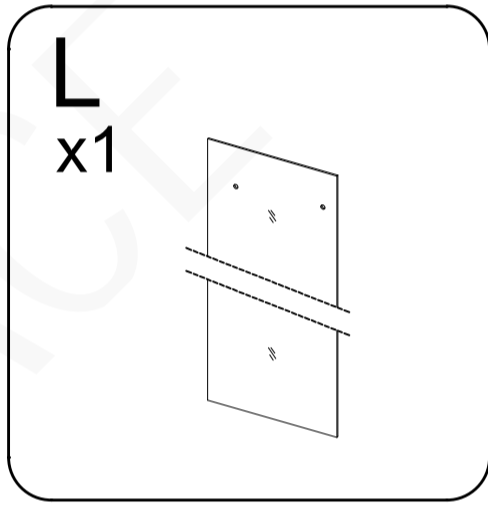
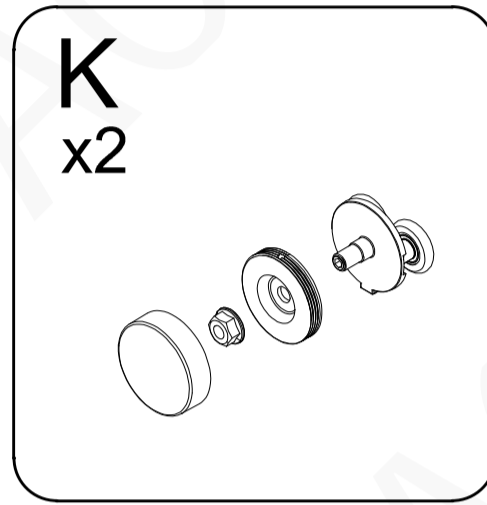
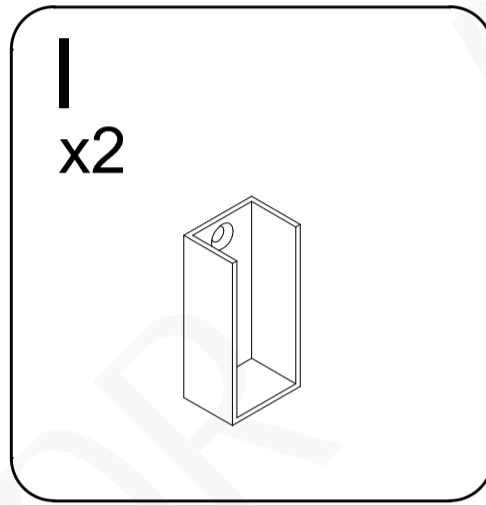
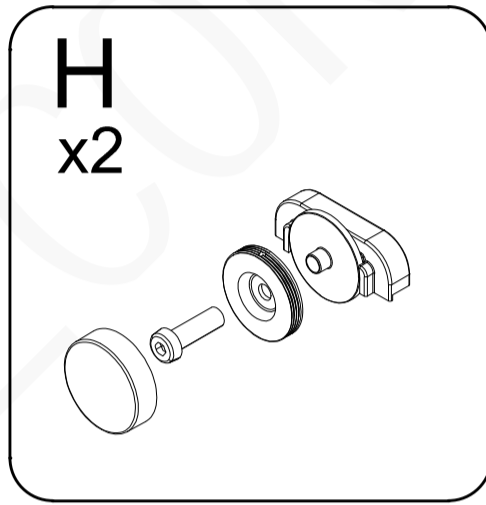
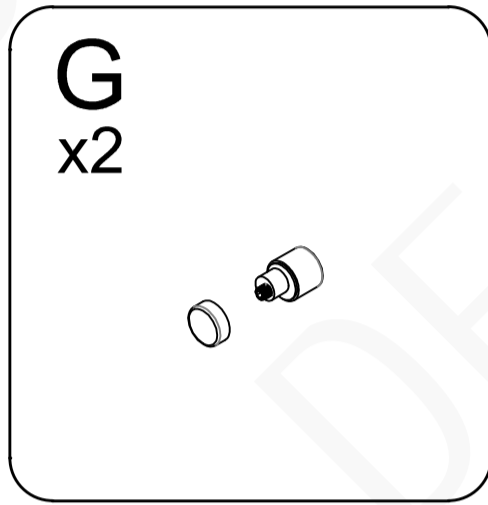
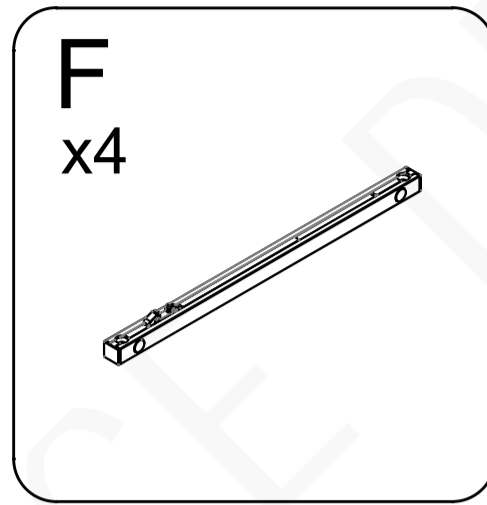
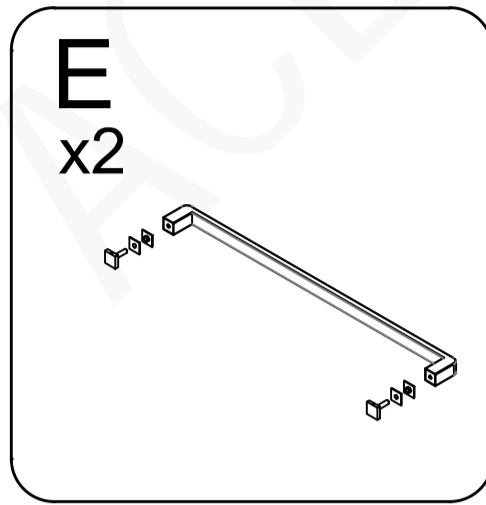
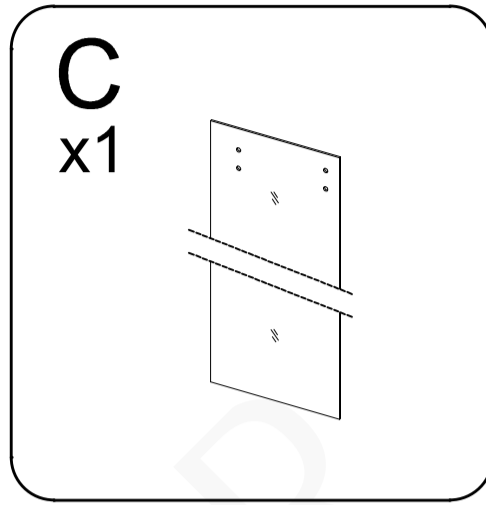
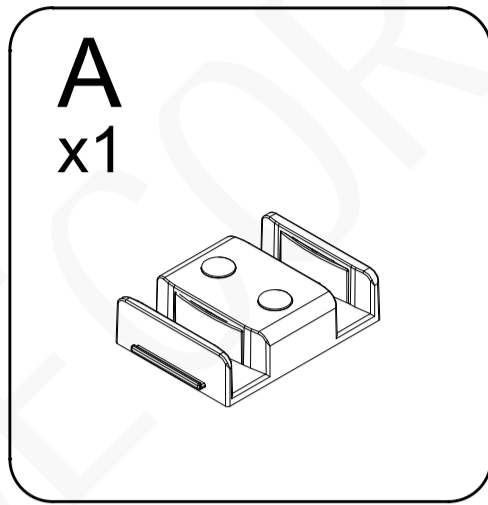

HARDWARE CONTENT

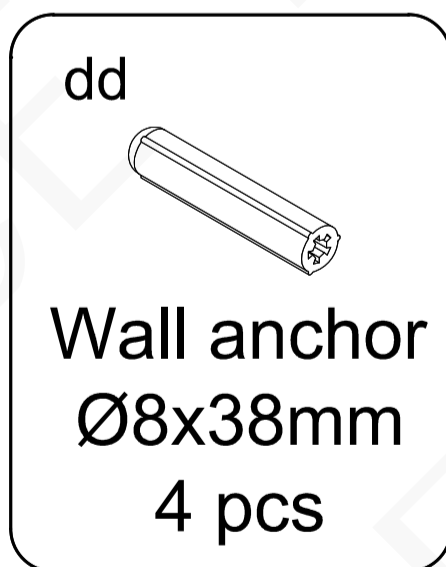
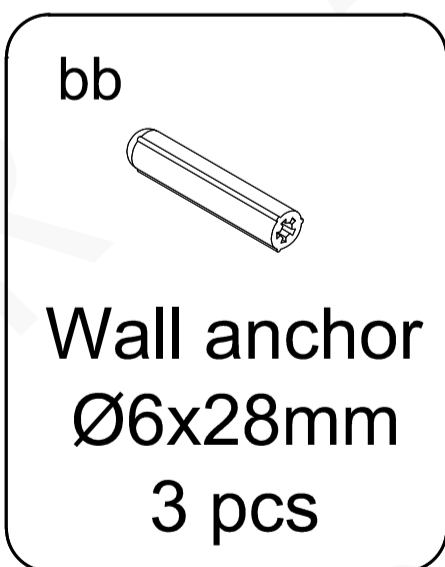

**NOTE: Inspect all parts for missing prior to installation!
Contact us for any part missing.**



CAUTION: To avoid personal injury or property damage, identify components and read all instructions before installing.

1 Measure the finished opening width.

IMPORTANT: Incorrect measurement may prevent proper door closure. Double-check measurement.

Before beginning installation, verify the door assembly will fit within the horizontal opening of the shower enclosure.

For the 60" door, the opening must be between 56" - 60".
For the 54" door, the opening must be between 50" - 54".
For the 60" door, the opening must be between 44" - 48".

Measure distance "W1" of upper shower enclosure opening and distance "W2" of lower shower enclosure opening.

Both measurements should be within the dimensions listed above for required opening widths.

W1 = Upper Enclosure Width
W2 = Lower Enclosure Width

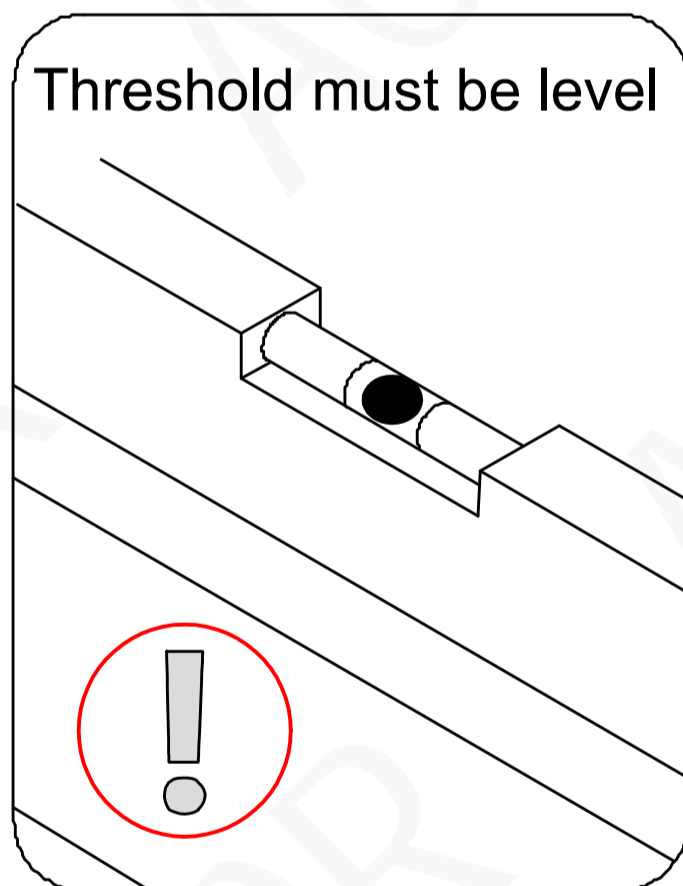
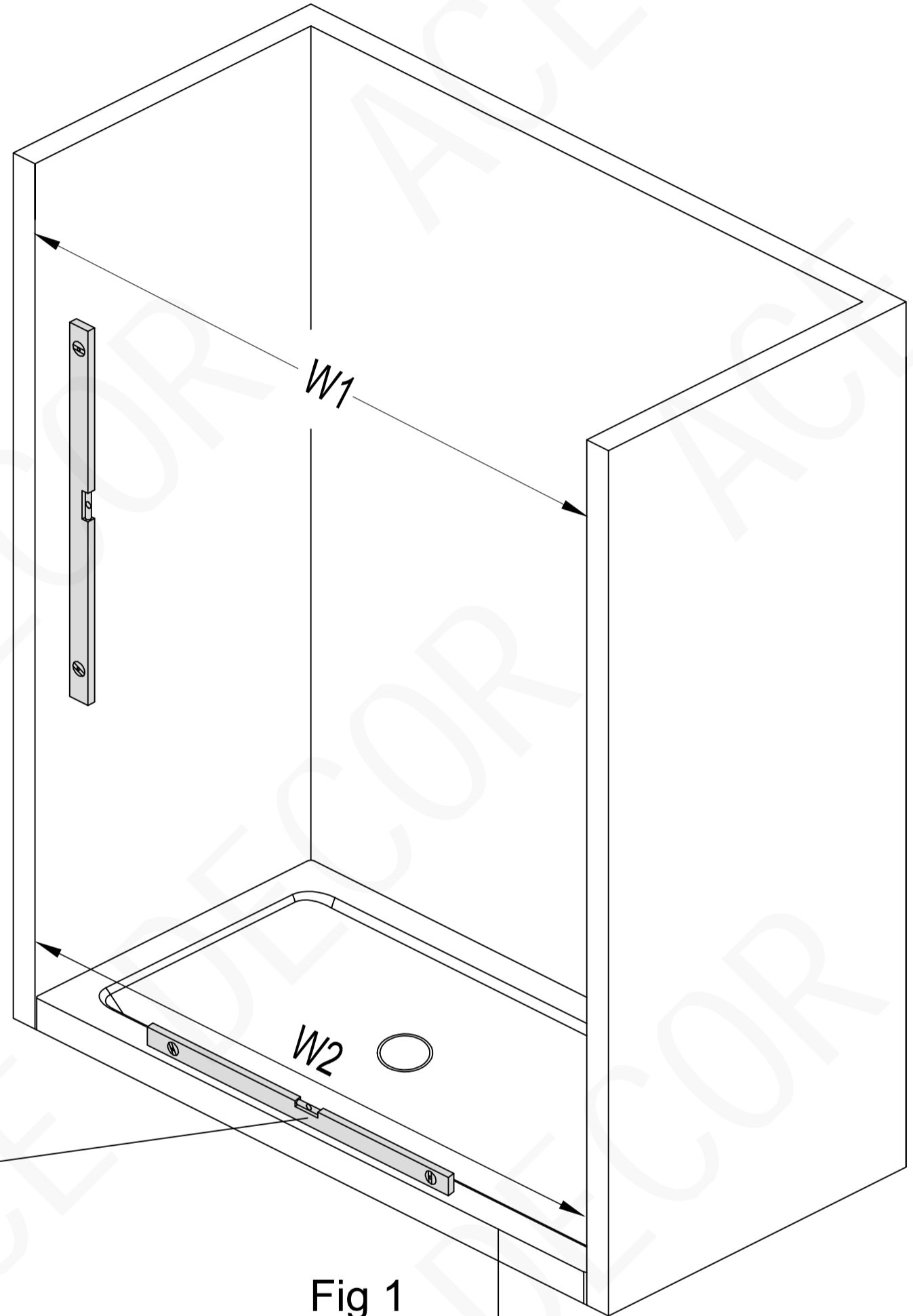
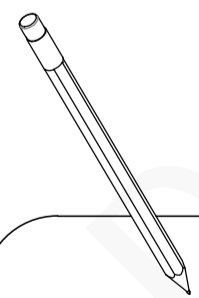

Fig 1



_____ Finished opening top (W1)
_____ Finished opening bottom (W2)

- 2 Cut the **Upper Guide Rail (J)** and the **Bottom Rail (B)** to fit your finished opening using either a miter saw or a hacksaw

Cut the Upper Guide Rail (J) to: "W1" (top) dimension minus 1/4"

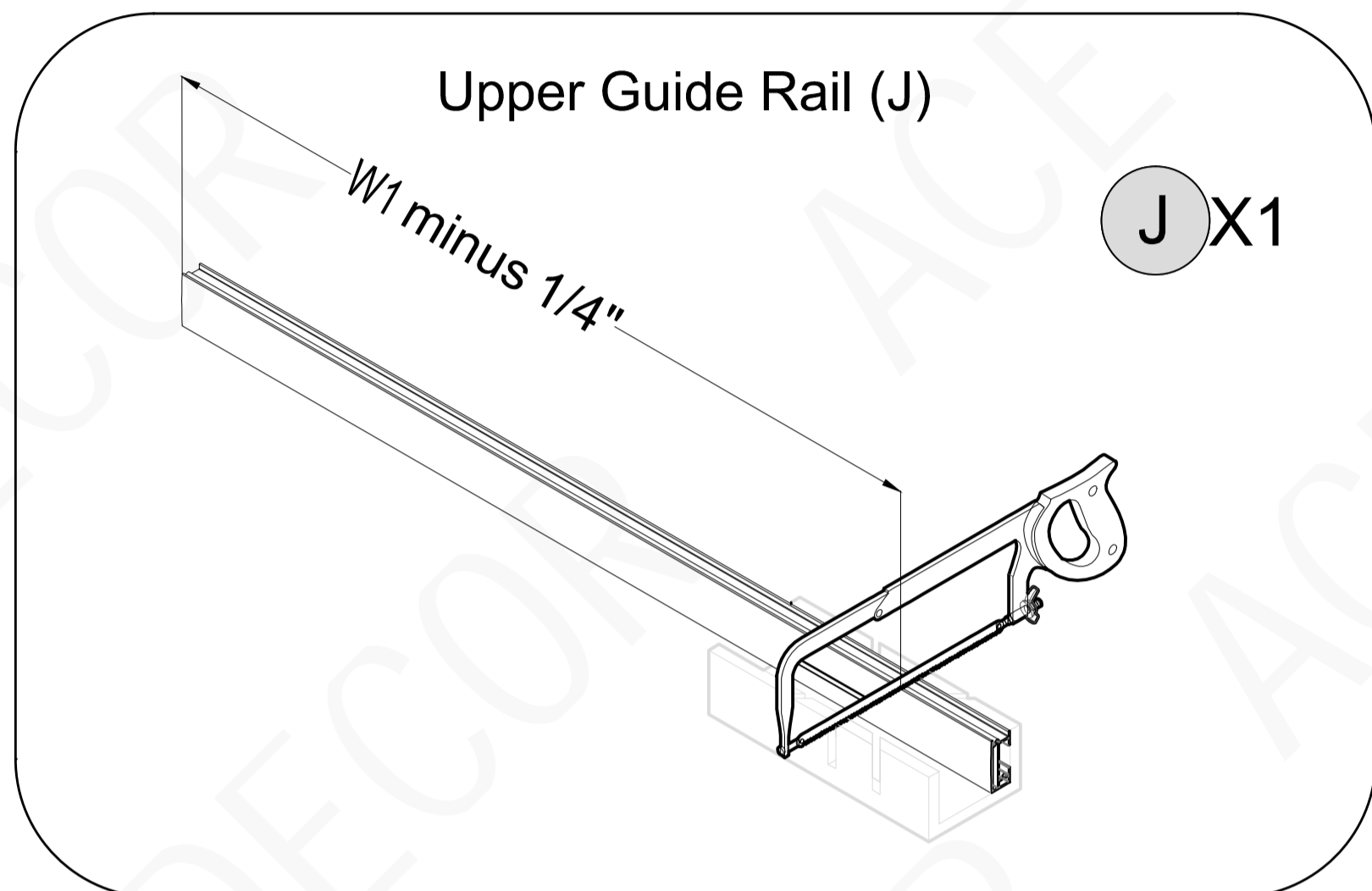

Cut the Bottom Rail (B) to: "W2"(bottom) dimension minus 1/16"
Use a metal file to remove any burrs from the cut ends.

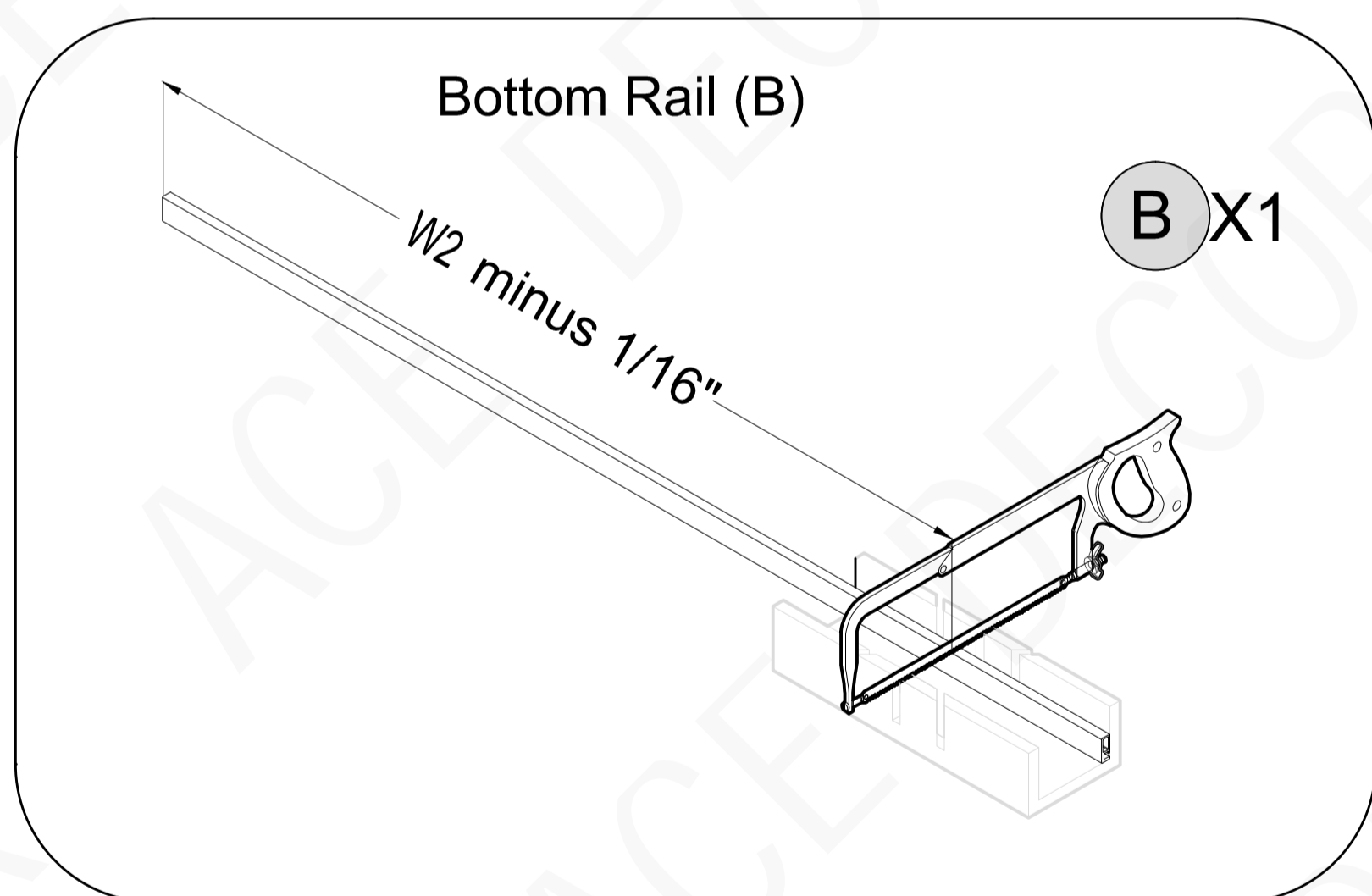

Fig 2

Only the Upper Guide Rail (J) and Bottom Rail (B) need to be cut to fit the finished opening size.



Wear safety glasses and cut-resistant, non-slip gloves when drilling or cutting to avoid risk of injury.

3 Wall Bracket (I) Installation

CAUTION: When cutting or drilling metal components or when handling glass, to reduce the risk of personal injury, protective eye wear, gloves, and closed-toe shoes are required.

1. Measure in 19/32" from the outside of the Templates(M) as Fig.1;
2. Position the **Templates(M)** on the wall(19/32" inside). Please note one end with 2 holes faces up. Mark the location of the holes as Fig.2;
3. Drill the holes as Fig.3 and Fig.4;
4. Attach the **Bracket(I)** to the wall as Fig.5.



- If a Stud is present behind the wall:
drill a $\text{Ø}5/32$ "(4mm) hole up to the stud, use the ST5 x 45 Countersunk Screws (cc) drill an $\text{Ø}1/8$ "(3mm) pilot hole into the stud and use the ST4.0 x 30mm Pan Head Screws (aa), attach the wall bracket assemblies .
OR
- If No Stud is present behind the wall:
drill a $\text{Ø}1/4$ "(6mm) hole and insert the wall anchors (bb) and use the ST4.0 x 30mm Pan Head Screws (aa).
drill a $\text{Ø}5/16$ " (8mm) hole and insert the wall anchors (dd) and use the ST5 x 45 Countersunk Screws (cc) attach the wall bracket assemblies .

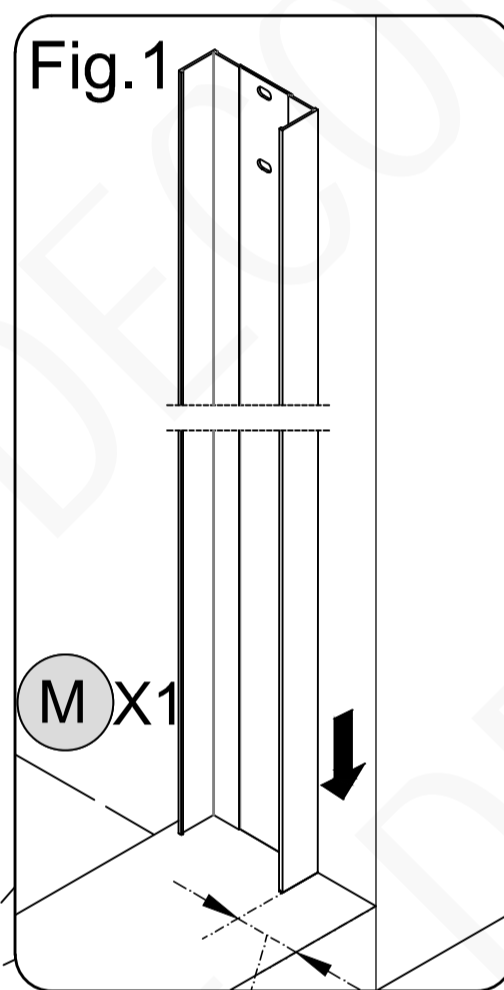
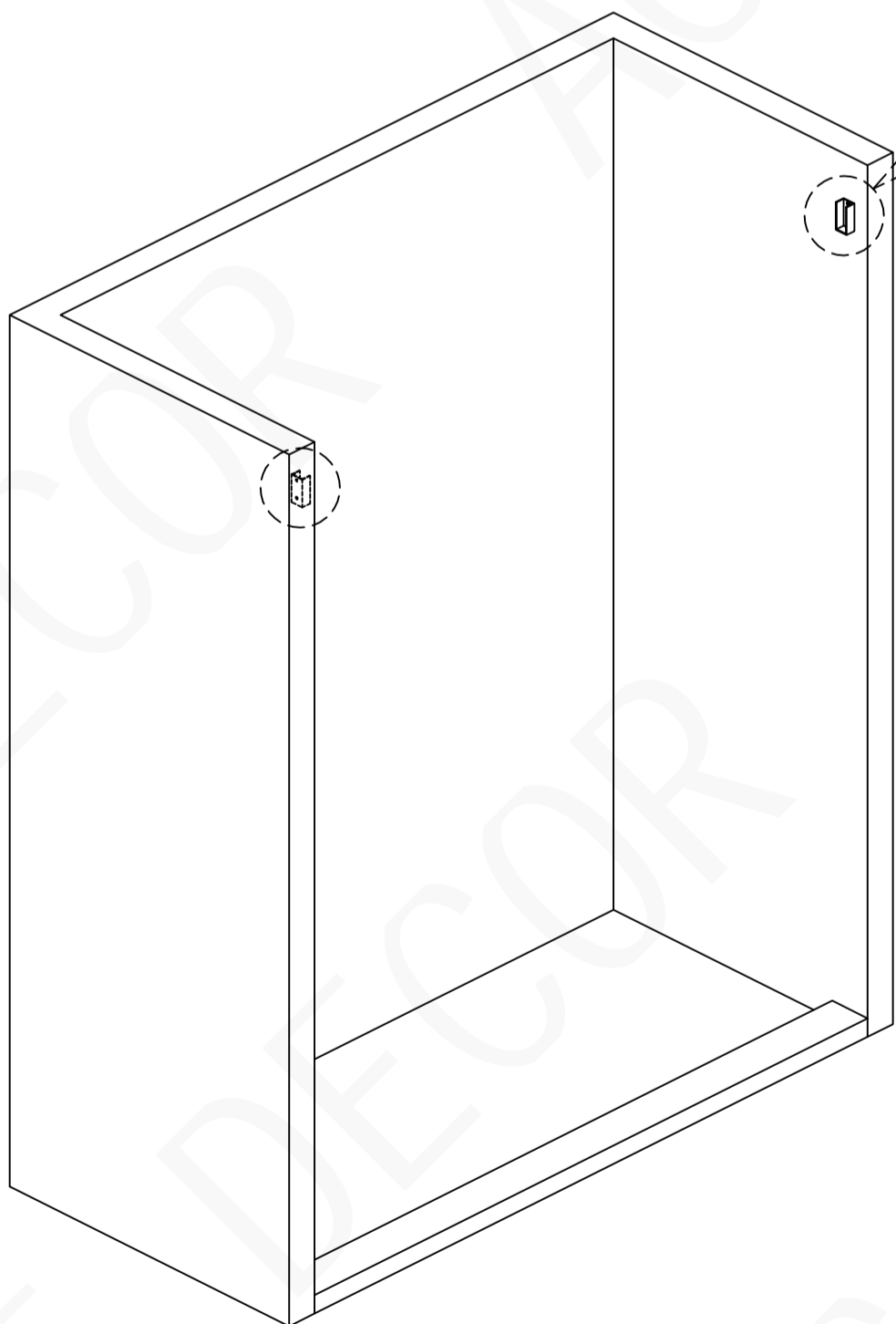

15mm [19/32"]

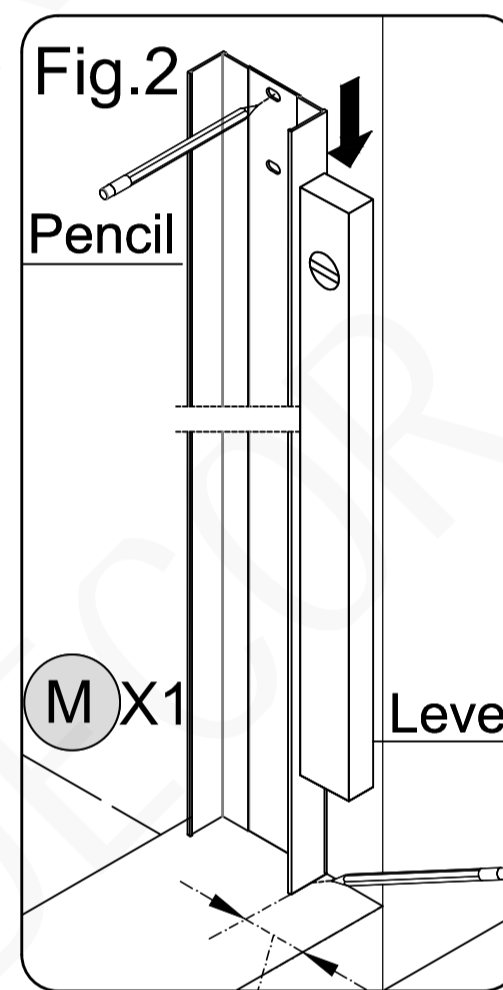

15mm [19/32"]

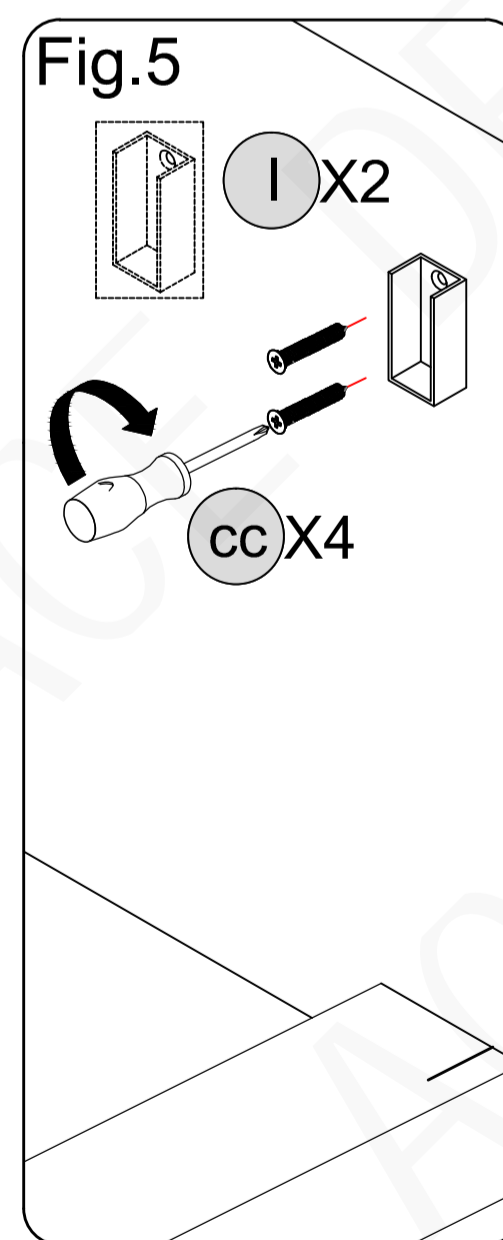
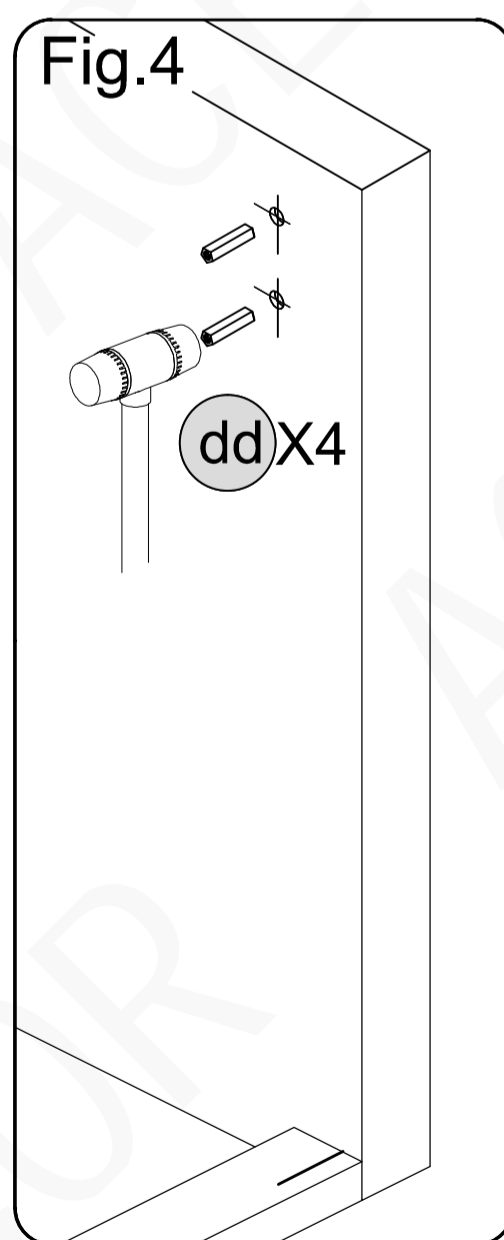
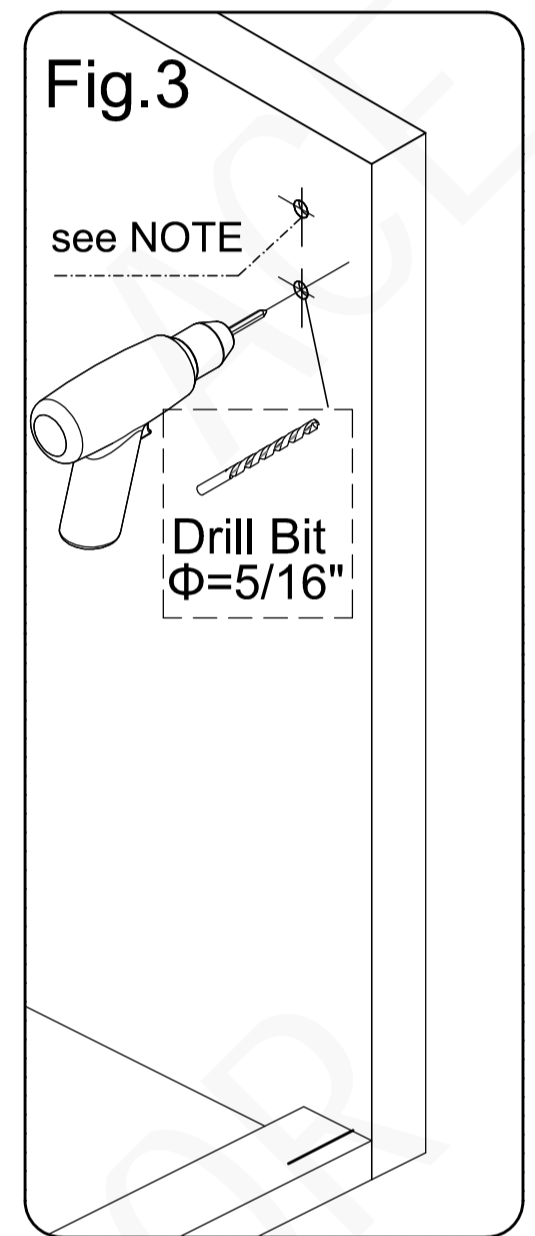

4 Inside Roller(K) & Anti-Fluctuator (F) Installation

1. Insert the **Inside Roller (K)** into **Upper Guide Rail (J)**.
2. First, push the bufer sliding hook to the designated position of **Anti-Fluctuator (F)** ,Insert the **Anti-Fluctuator (F)** into **Upper Guide Rail (J)**.
3. Adjust the **Anti-Fluctuator (F)** on the **Upper Guide Rail (J)**, as Fig.2.

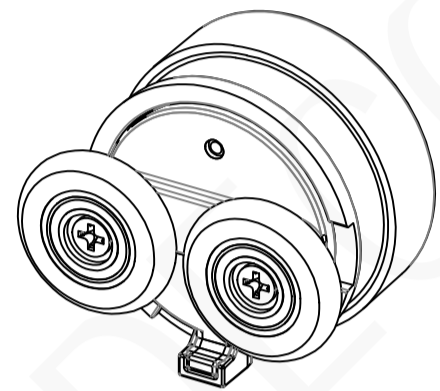

Inside Roller (K)

Fig.1 Insert K to J

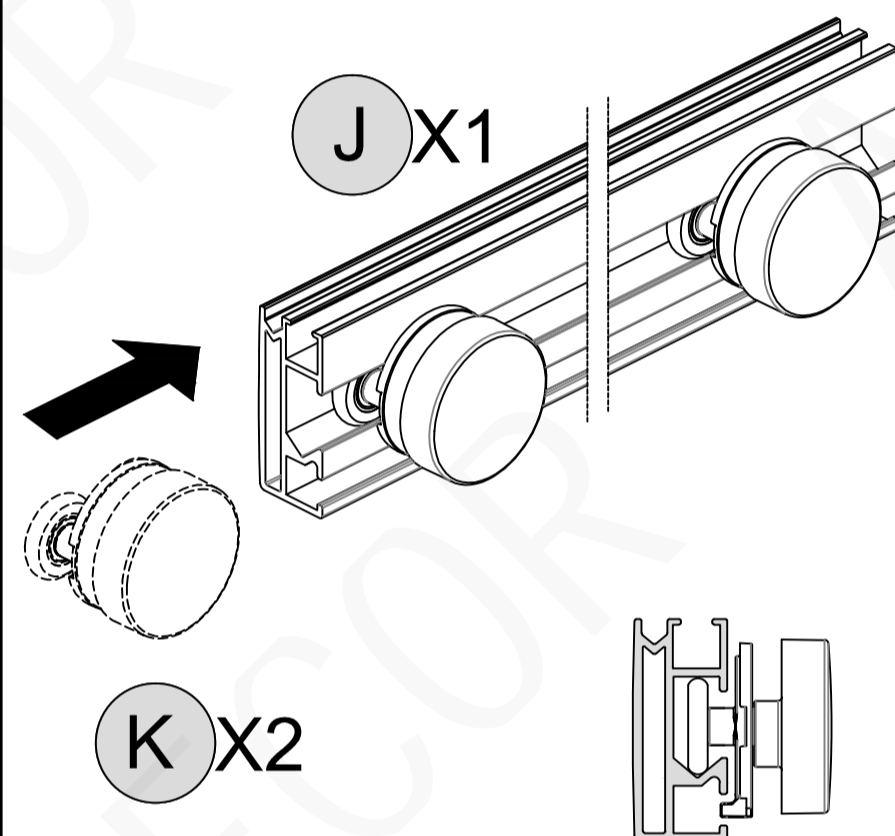
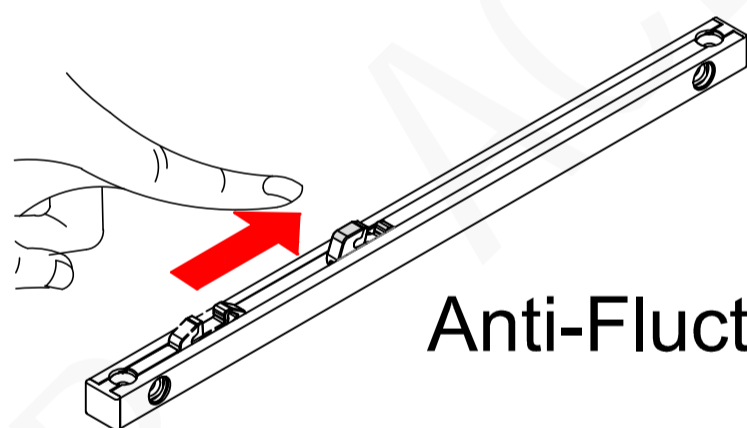

Fig.2

NOTE

First, push the bufer sliding hook to the designated position



Anti-Fluctuator (F)

Insert F to J

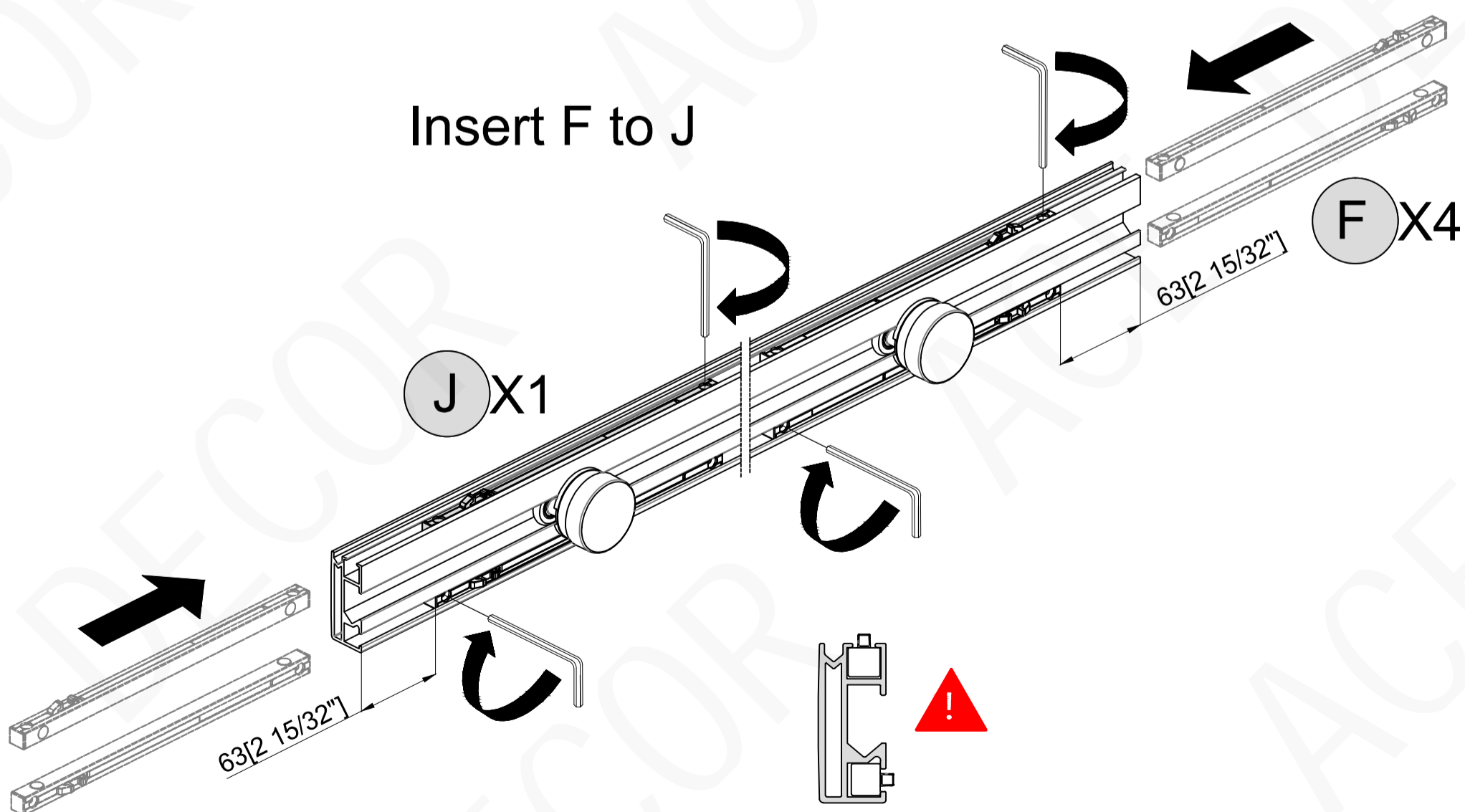

5 Upper Guide Rail (J) Installation

1. Insert the **Upper Guide Rail (J)** into the installed **Wall Bracket Assembly (I)**.

NOTE

Put **Inside Glass Panel (L)** inside the shower place before install the **Upper Guide Rail(J)**, and the green label faces outside.

2 holes on the top!

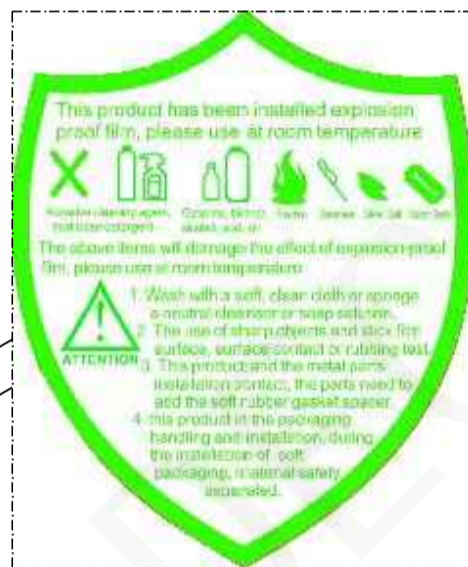
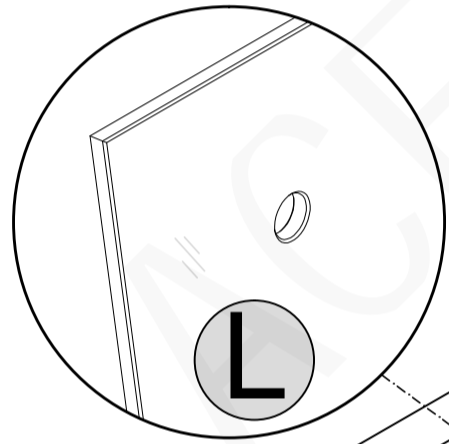

see Label

Check the Upper Guide Rail for level.

L

Lay the glass on a soft padded surface!

Fig.1

Insert J to I

J X1

I X2

- 6 Bottom guide (A) can be installed on acrylic bathtub or stone bathtub. Please choose the installation method according to the bathtub type.

6-1 Bottom guide (A) installed on Acrylic bathtub

CAUTION: When cutting or drilling metal components or when handling glass, to reduce the risk of personal injury, protective eye wear, gloves, and closed-toe shoes are required.

Measure across the width of the threshold to locate and mark the center.

Drill a $\text{Ø}1/8"$ (3mm) hole and use the ST4.0 x 30mm Pan Head **Screws (aa)**.

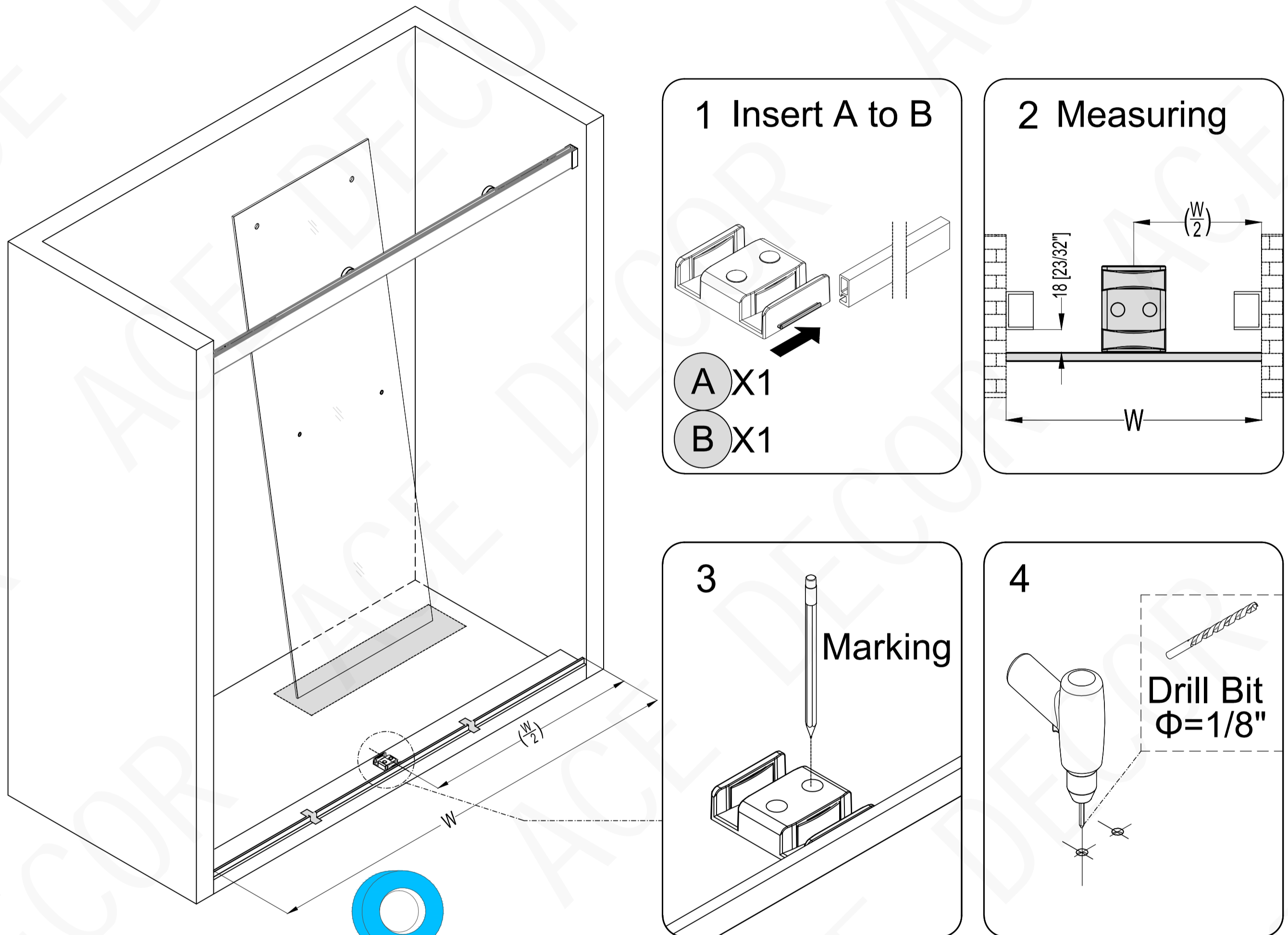

Use Painter's Tape to hold the Water seal

- 1、 Slide the **Bottom Guide(A)** to the **Bottom Rail(B)**.
- 2、 Position the **Bottom Guide(A)** to the middle of shower door. Put the **Bottom Rail(B)** $23/32"$ away from **Wall Bracket (I)**.
- 3、 Mark the holes.
- 4、 Drill holes.
- 5、 Install the **Screws(aa)**.

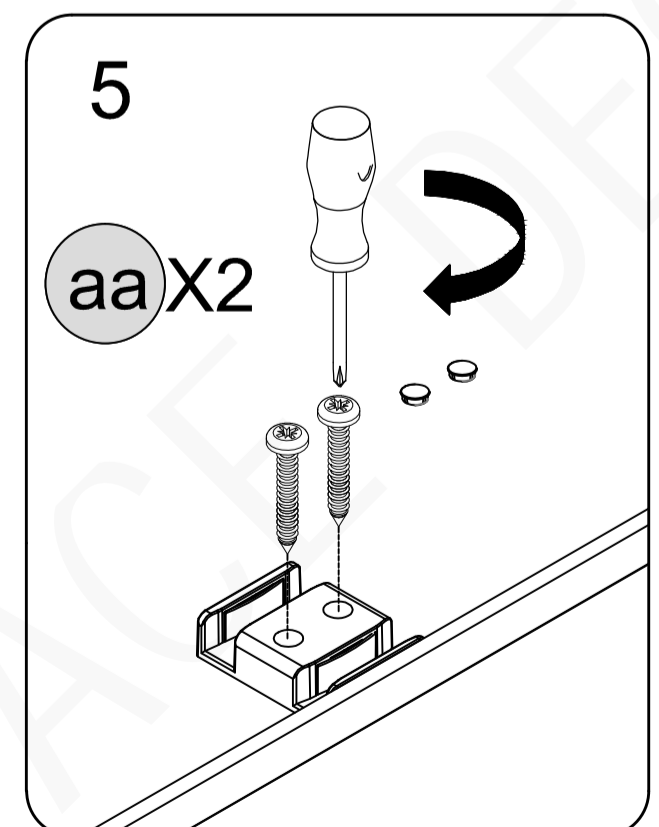

6-2 Bottom guide (A) installed on stone bathtub & Bottom Rail Installation

CAUTION: When cutting or drilling metal components or when handling glass, to reduce the risk of personal injury, protective eye wear, gloves, and closed-toe shoes are required.

Measure across the width of the threshold to locate and mark the center.

Drill a $\text{Ø}1/4"$ (6mm) hole and insert the **Wall Anchors (bb)** and use the ST4.0 x 30mm Pan Head **Screws (aa)**.

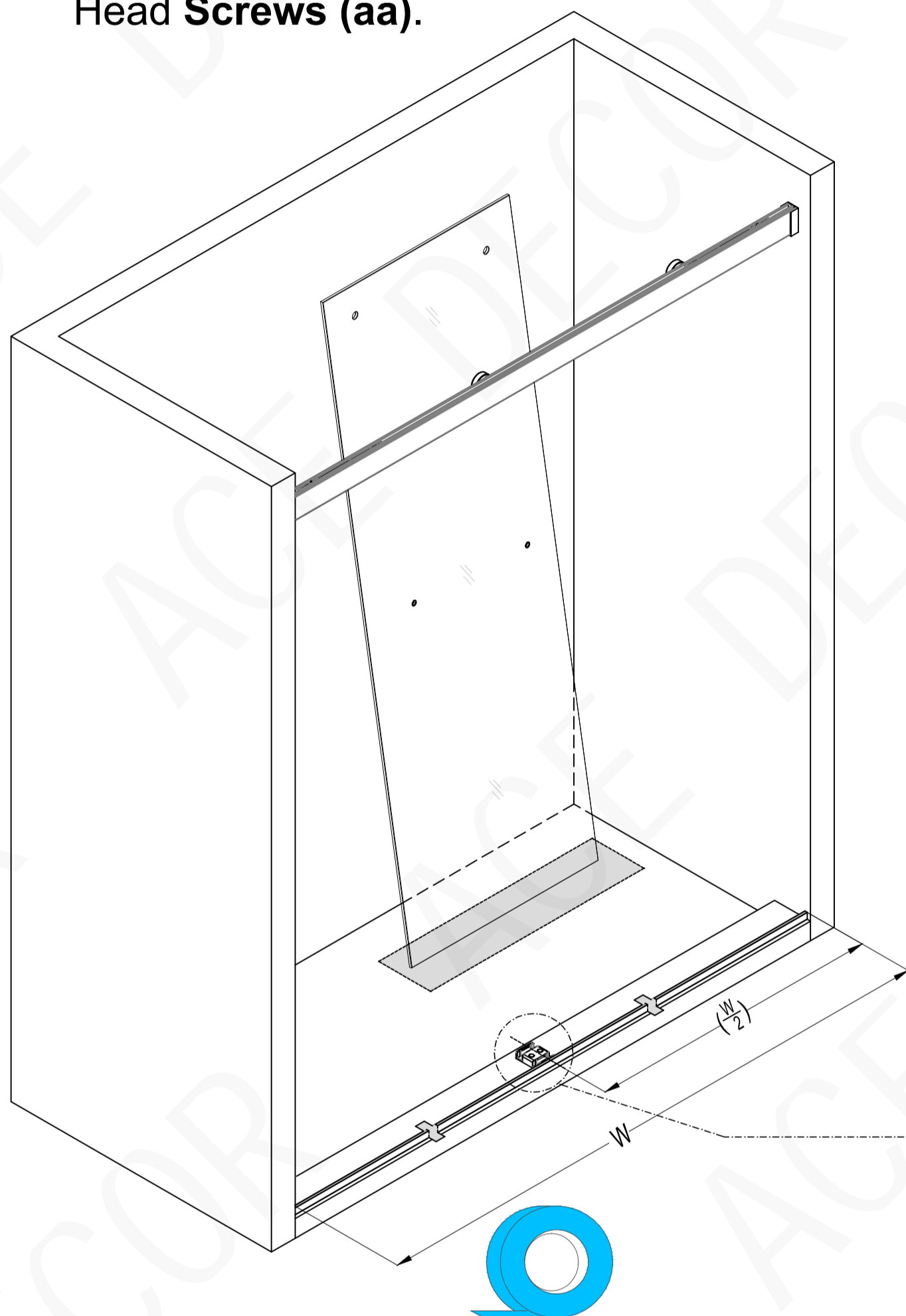

1 Insert A to B

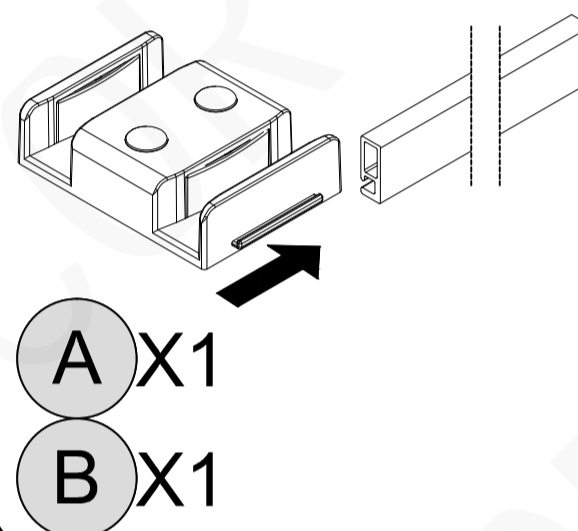

2 Measuring

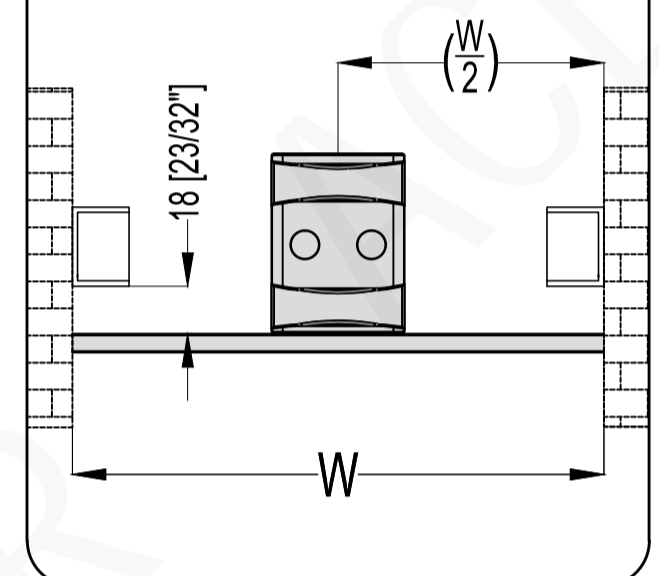

3

Marking

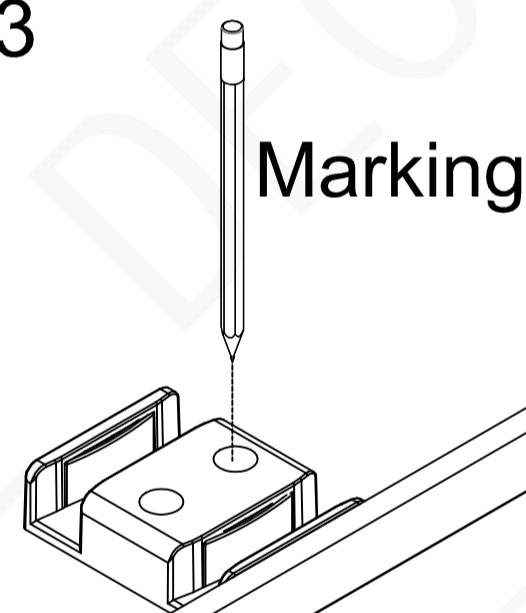

4

Drill Bit
 $\text{Ø} = 1/4"$

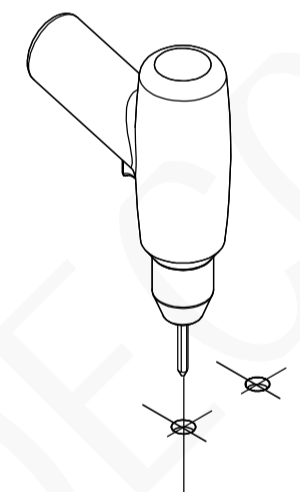

Use Painter's Tape to hold the Water seal

- 1、 Slide the **Bottom Guide(A)** to the **Bottom Rail(B)**.
- 2、 Position the **Bottom Guide(A)** to the middle of shower door.
Put the **Bottom Rail(B)** next to the outside of two **Wall jambs(E)**.
- 3、 Mark the holes.
- 4、 Drill holes.
- 5、 Insert the **Wall Anchors(cc)**.
- 6、 Install the **Screws(bb)**.

5

bb X2

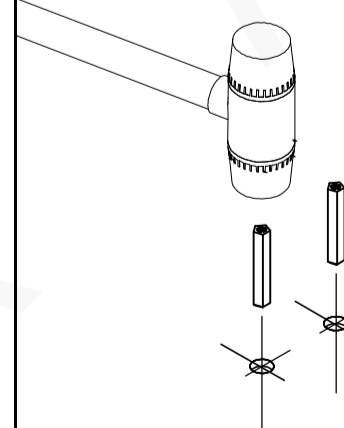

6

aa X2

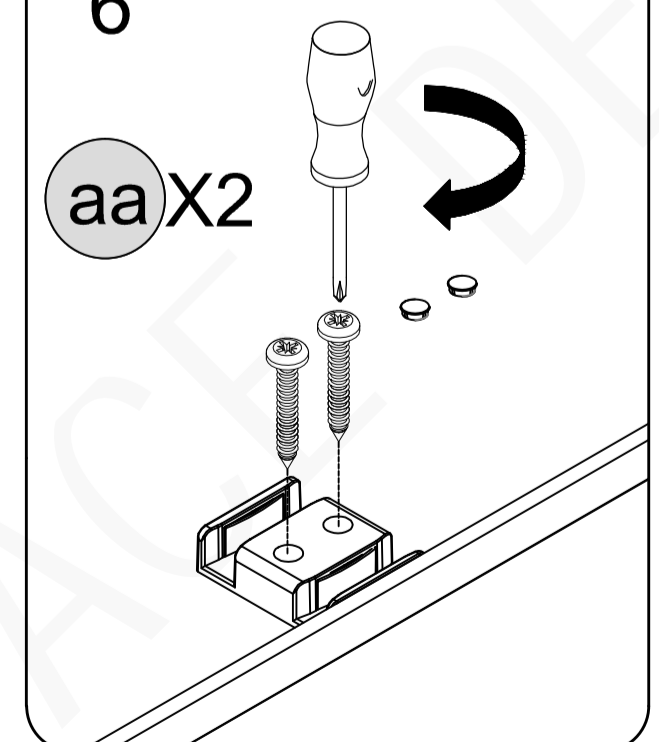

7 Inside Door panel (L) Installation

CAUTION: When cutting or drilling metal components or when handling glass, to reduce the risk of personal injury, protective eye wear, gloves, and closed-toe shoes are required.

DO NOT install the towel bars on the glass until instructed.

DO NOT lift the glass using the towel bars.

This could result in damage to the glass and/or serious personal injury.

Always use an assistant or a professional grade glass suction cup when handling heavy glass.

1. Insert the **Inside Door Panel(L)** into the **Bottom Guide(A)** as Fig.1.

2. Remove the cap and screw from the **Rollers (K)** and attach the **Rollers (K)** to the **Inside Door Panel(L)** Fig.2

3. Adjust rollers up or down to make sure the door align with wall as Fig.3.

4. Fasten the screw nut as Fig.4.

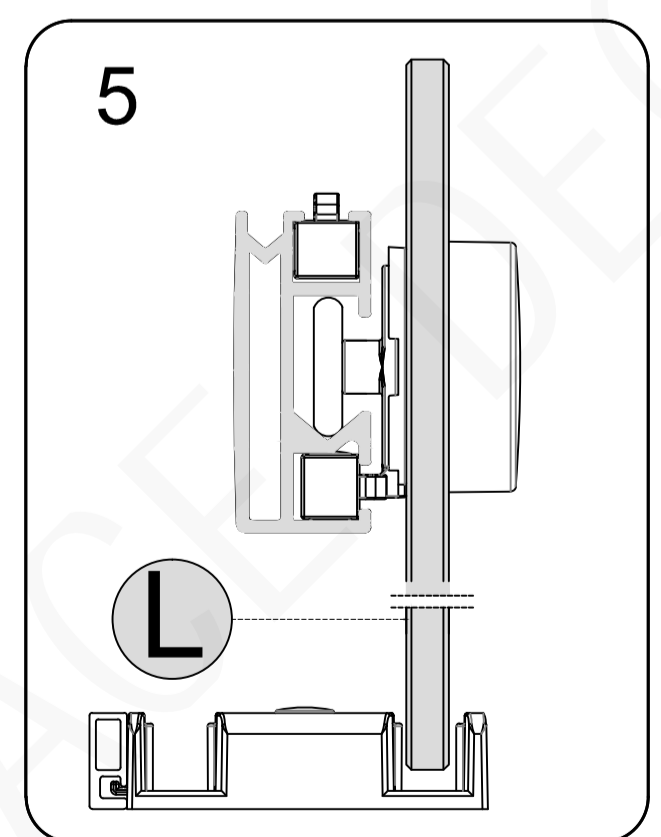
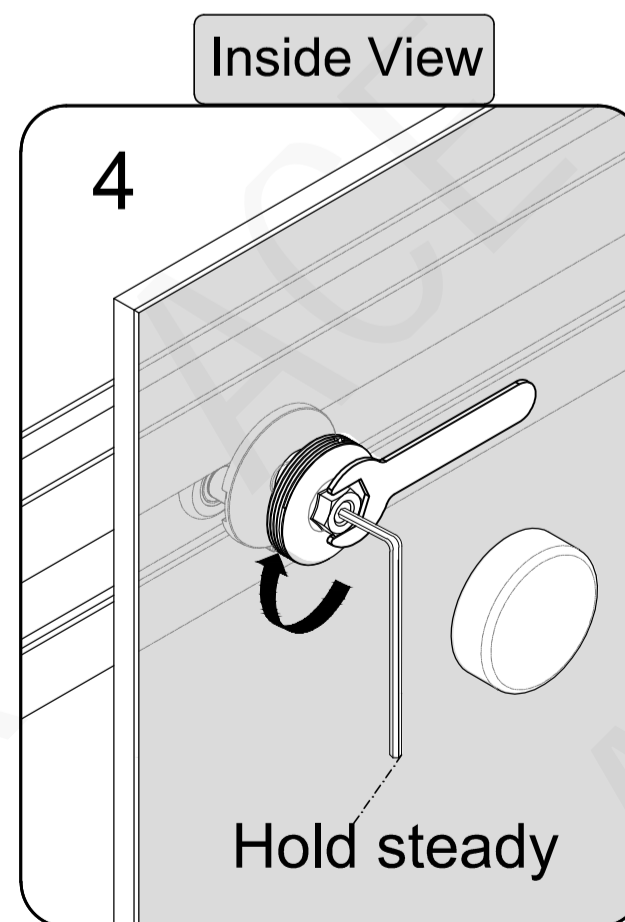
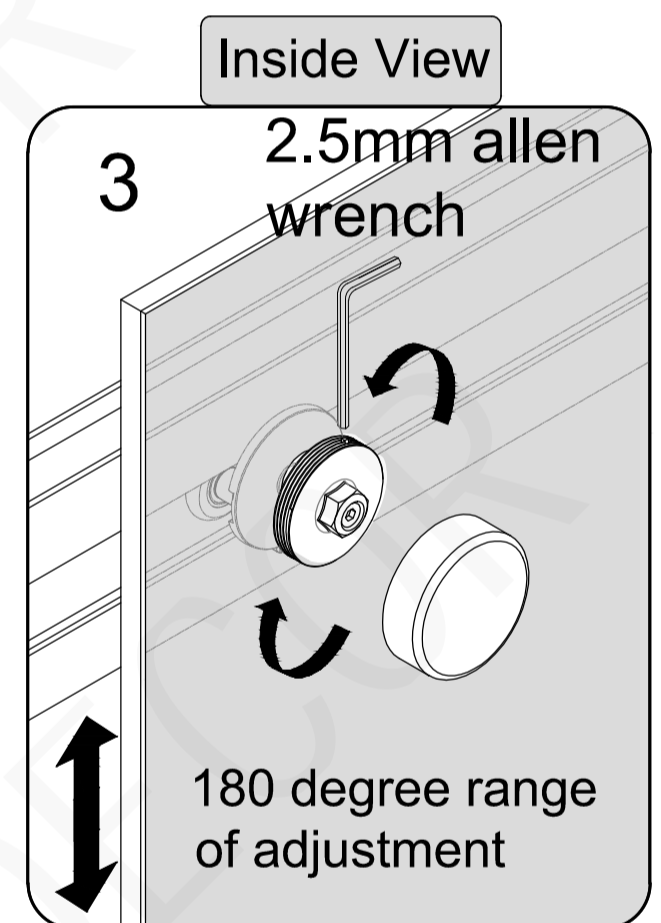
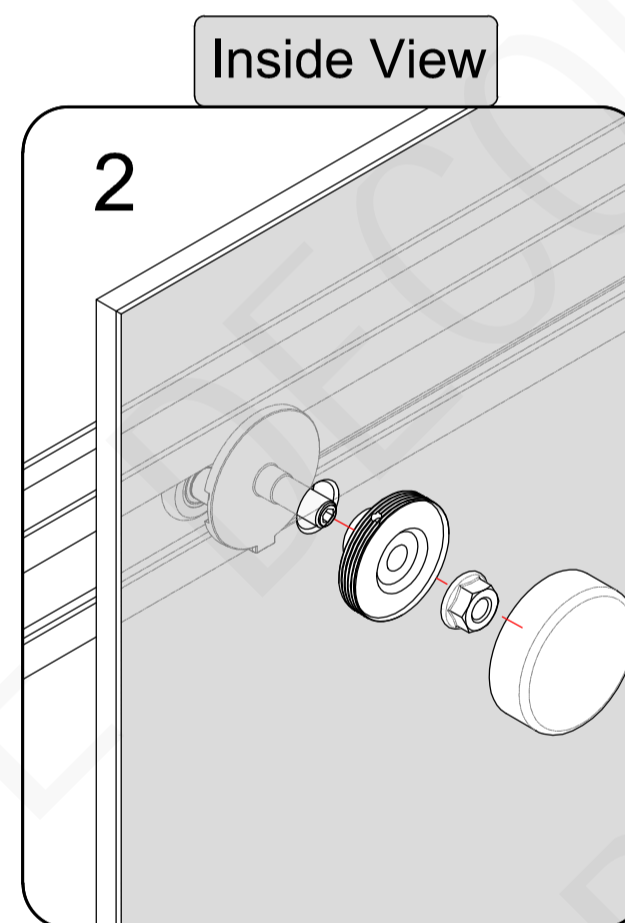
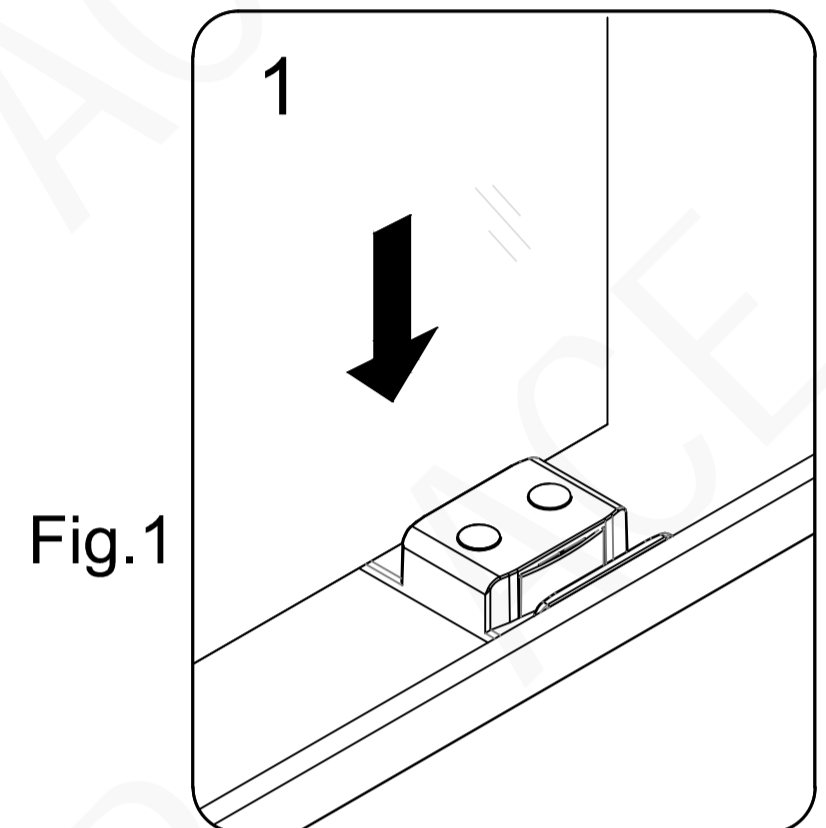
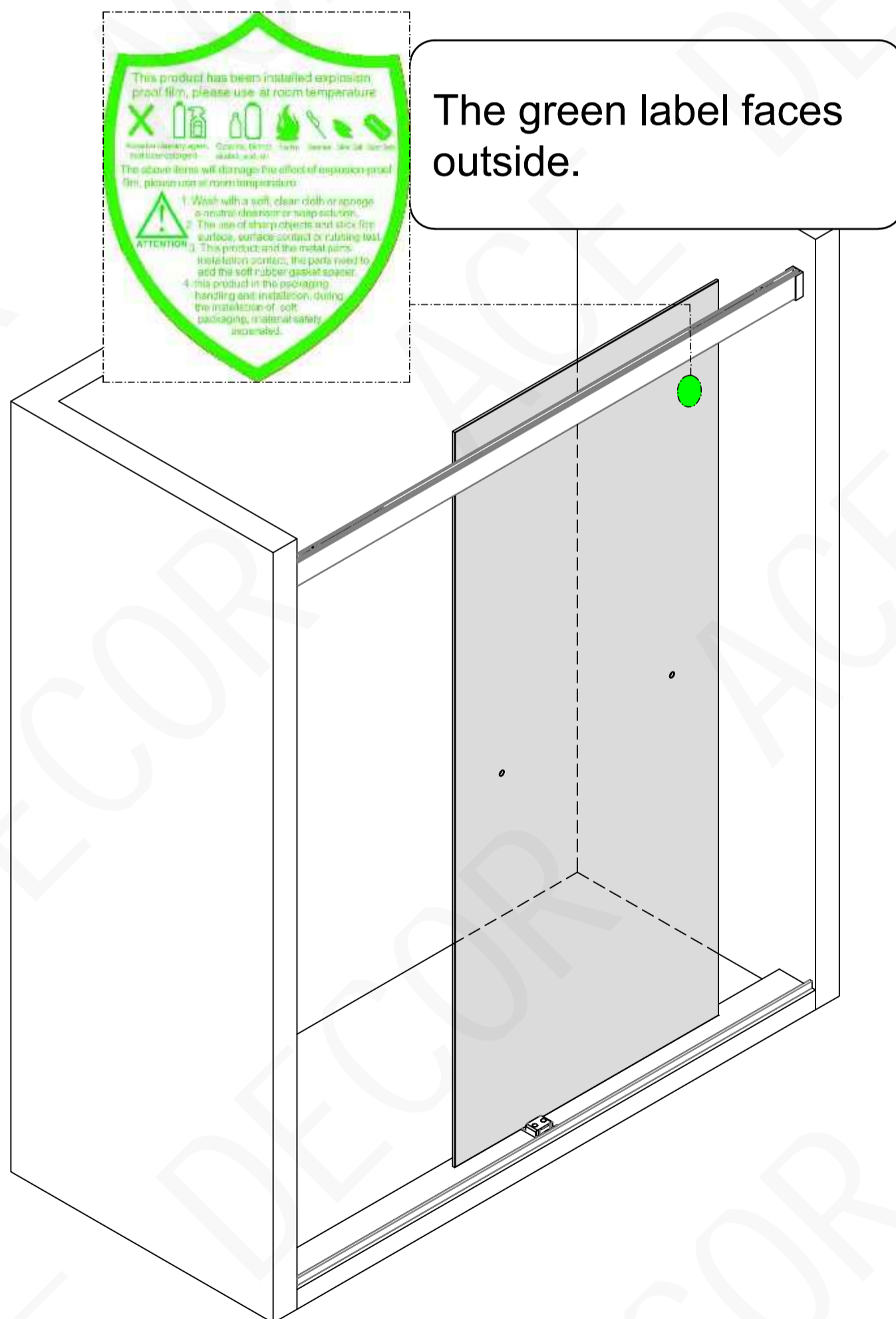

7-1 Outside Door panel (C) & Outside Roller (H) Installation

CAUTION: When cutting or drilling metal components or when handling glass, to reduce the risk of personal injury, protective eye wear, gloves, and closed-toe shoes are required.

DO NOT install the towel bars on the glass until instructed.

DO NOT lift the glass using the towel bars.

This could result in damage to the glass and/or serious personal injury.

Always use an assistant or a professional grade glass suction cup when handling heavy glass.

Remove the cap and screw from the **Rollers (H)** and attach the **Rollers (H)** to the **Outside Door Panel (C)**.

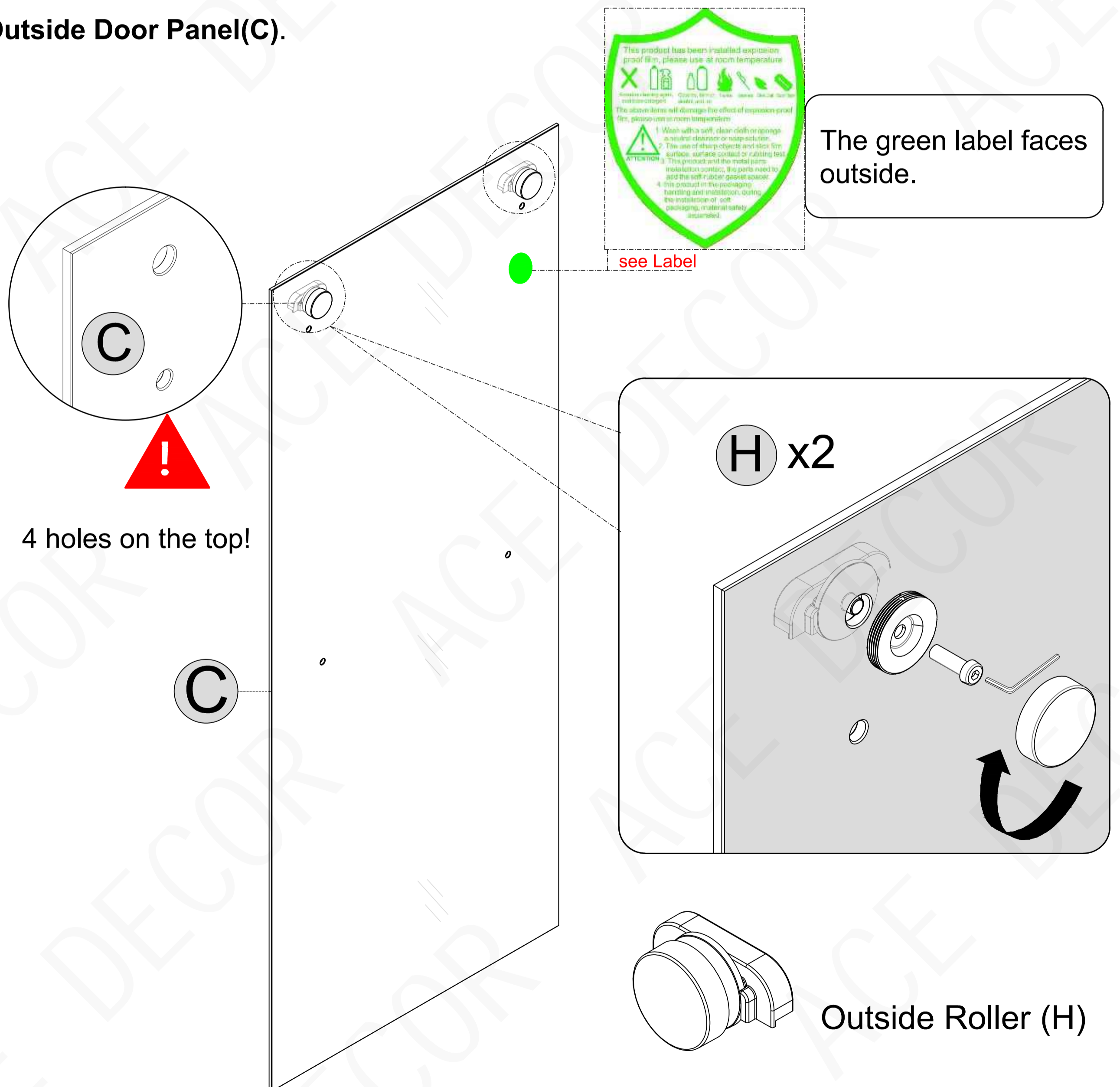

7-2 Outside Door panel (C) & Outside Roller (H) Installation

CAUTION: When cutting or drilling metal components or when handling glass, to reduce the risk of personal injury, protective eye wear, gloves, and closed-toe shoes are required.

The green label faces outside.



see Label

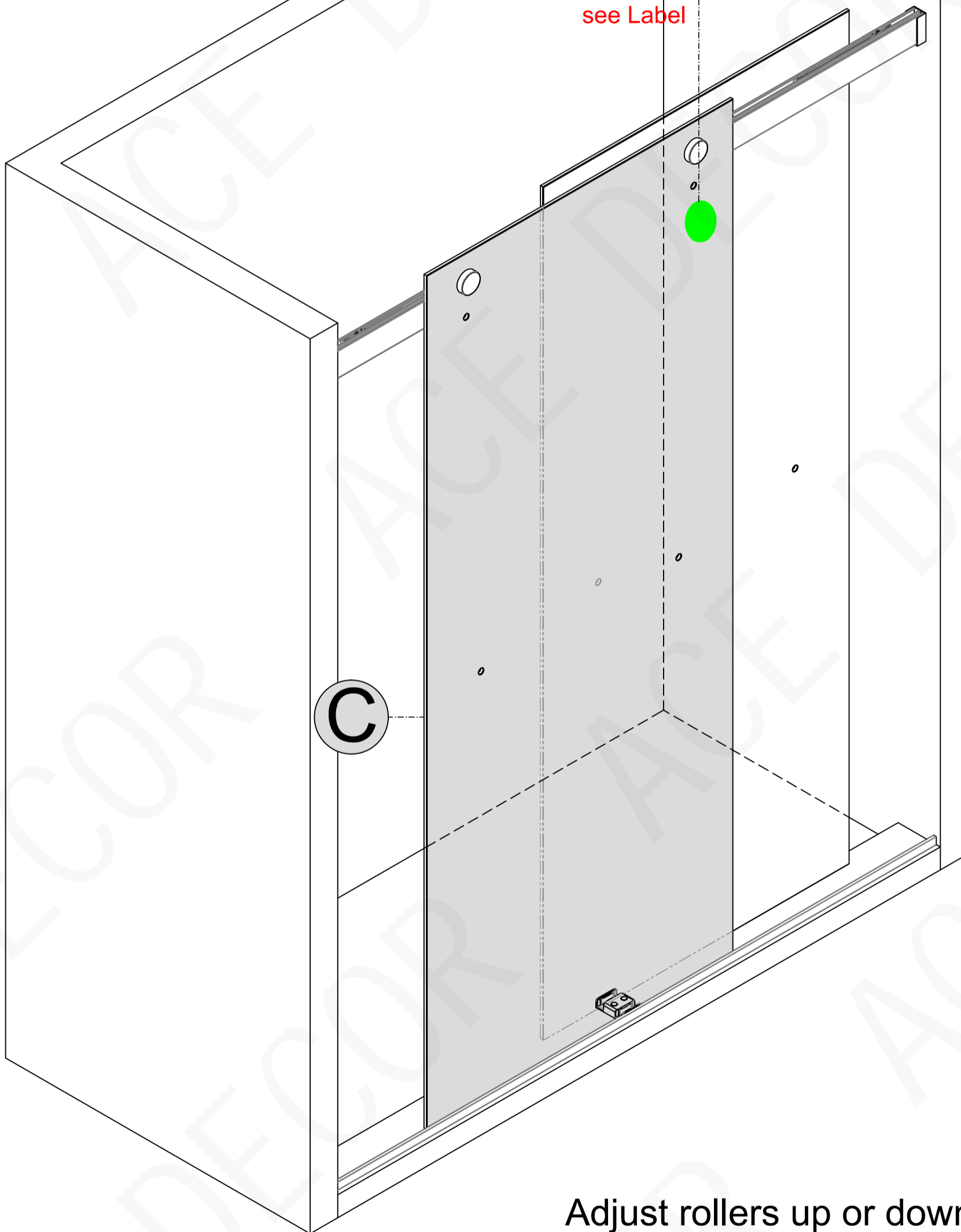

Adjust rollers up or down so door aligns with wall.

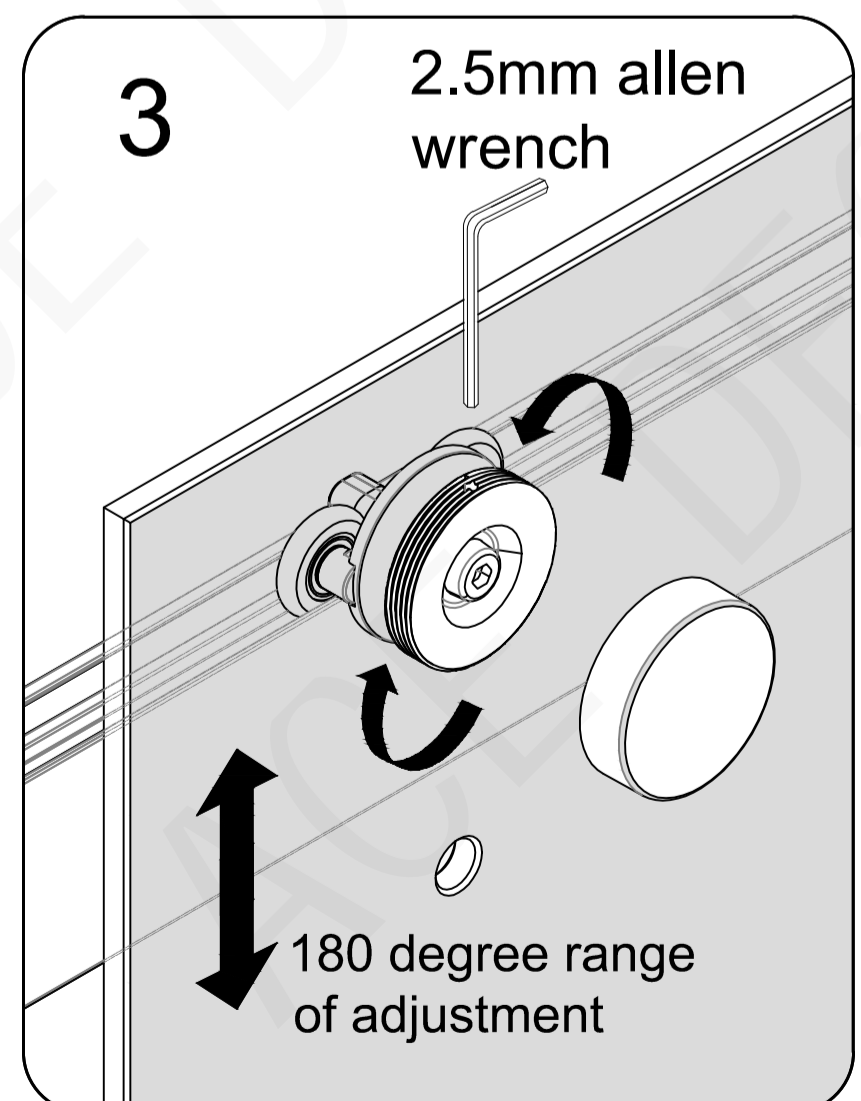
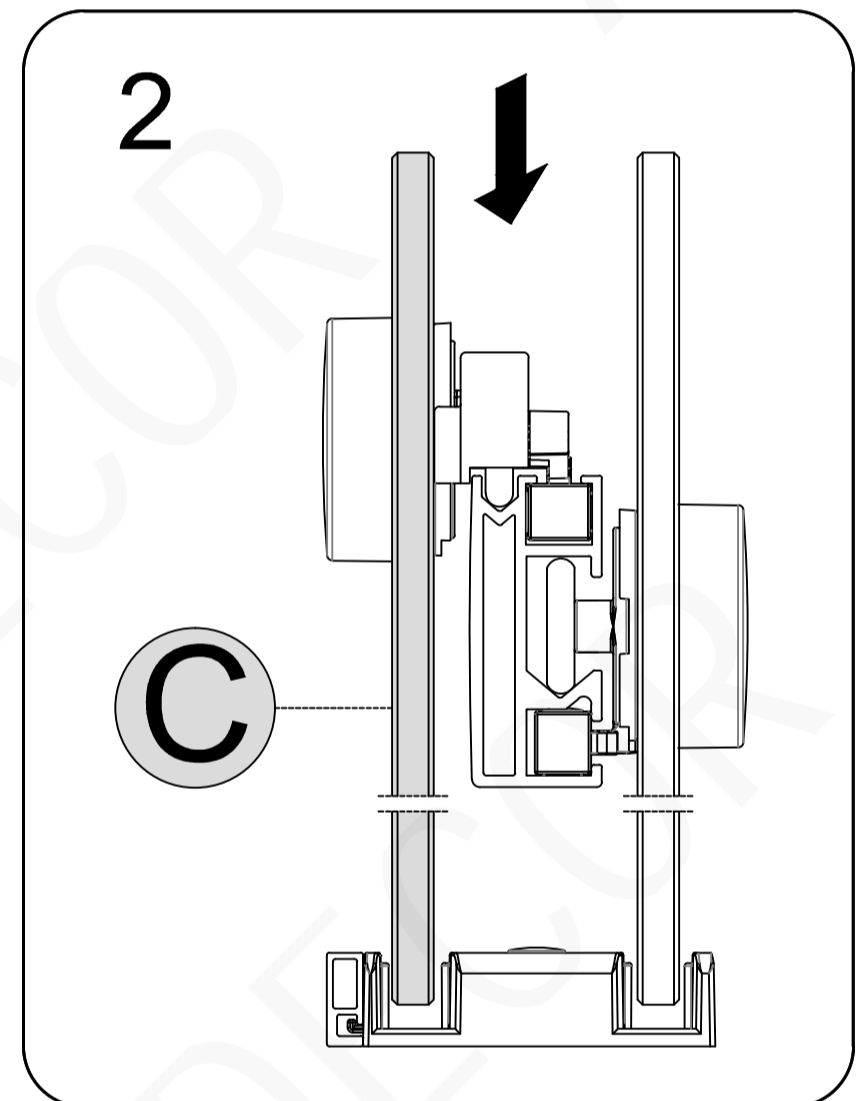
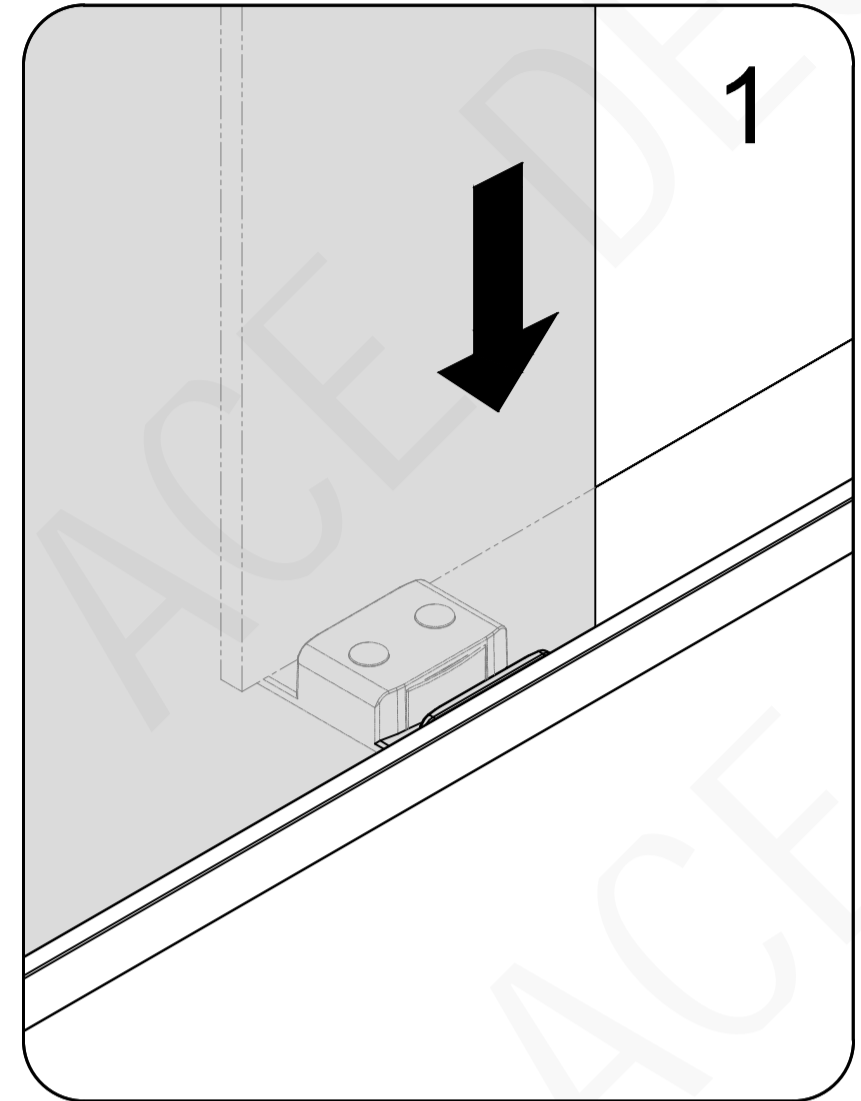

8 Anti-jump assembly (G) Installation

CAUTION: When cutting or drilling metal components or when handling glass, to reduce the risk of personal injury, protective eye wear, gloves, and closed-toe shoes are required.

Attach the **Anti-jump Assembly (G)** to the **Outside Door Glass (C)** to prevent the door glass from being lifted off of the **Upper Guide Rail (J)**. Adjust the **Anti-jump Assembly (G)** to within $1/32$ " beneath the **Upper Guide Rail (J)**.

NOTE

If you notice there is no buffering effect after everything is installed, it is mainly caused by the rebound of the buffer sliding hook in the upper guide rail. A finger to push the buffer sliding hook to the designated position, so that the end of the shank can slide into the buffer and slide together. as Pag.9 of Fig.2

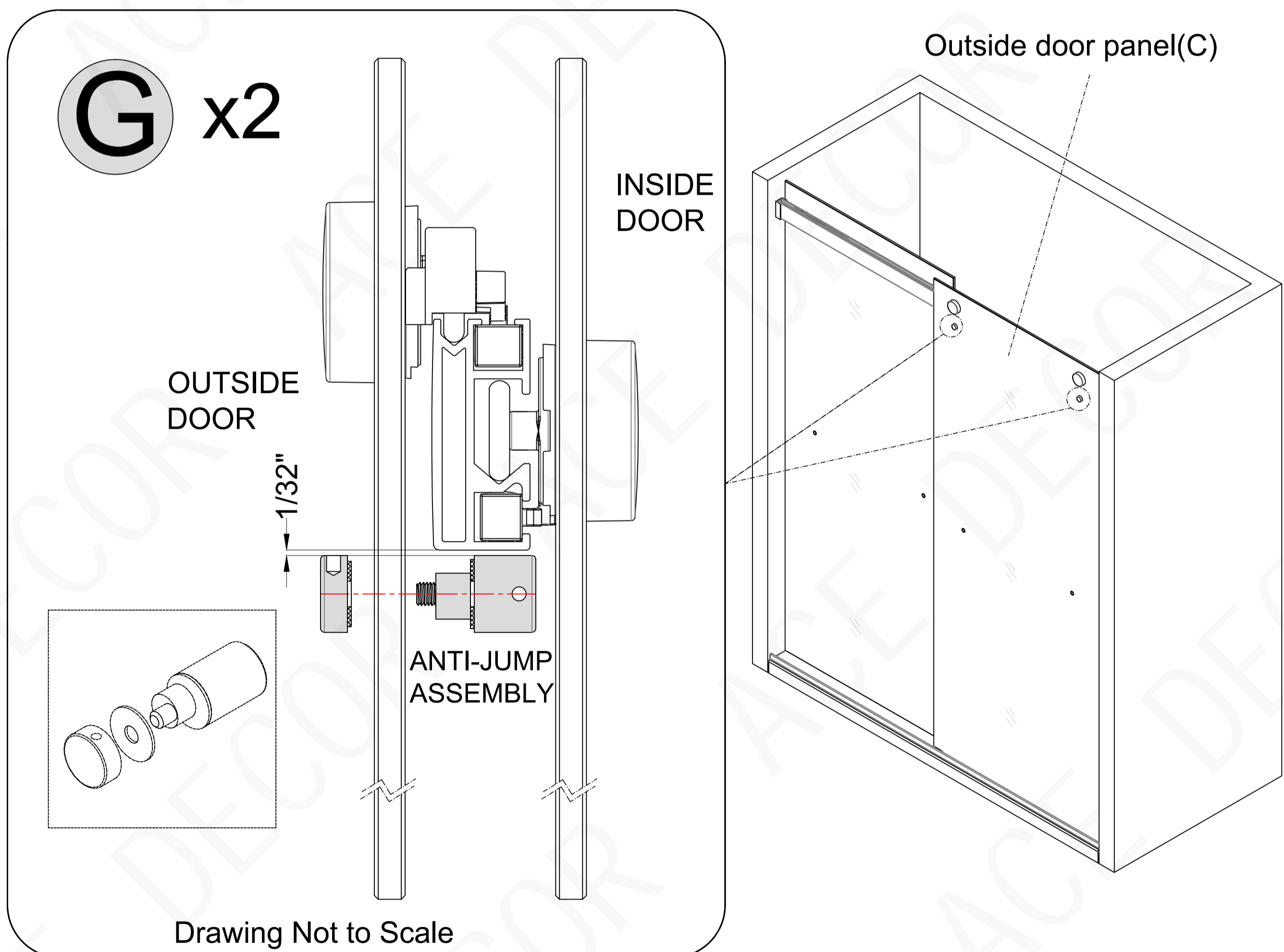

9 Handle (E) Installation

Attach the **Handle (E)** to the **Inside Door Panel (L)** and to the **Outside Door Panel (C)**. Be sure to use all of the supplied rubber gaskets to protect the glass.

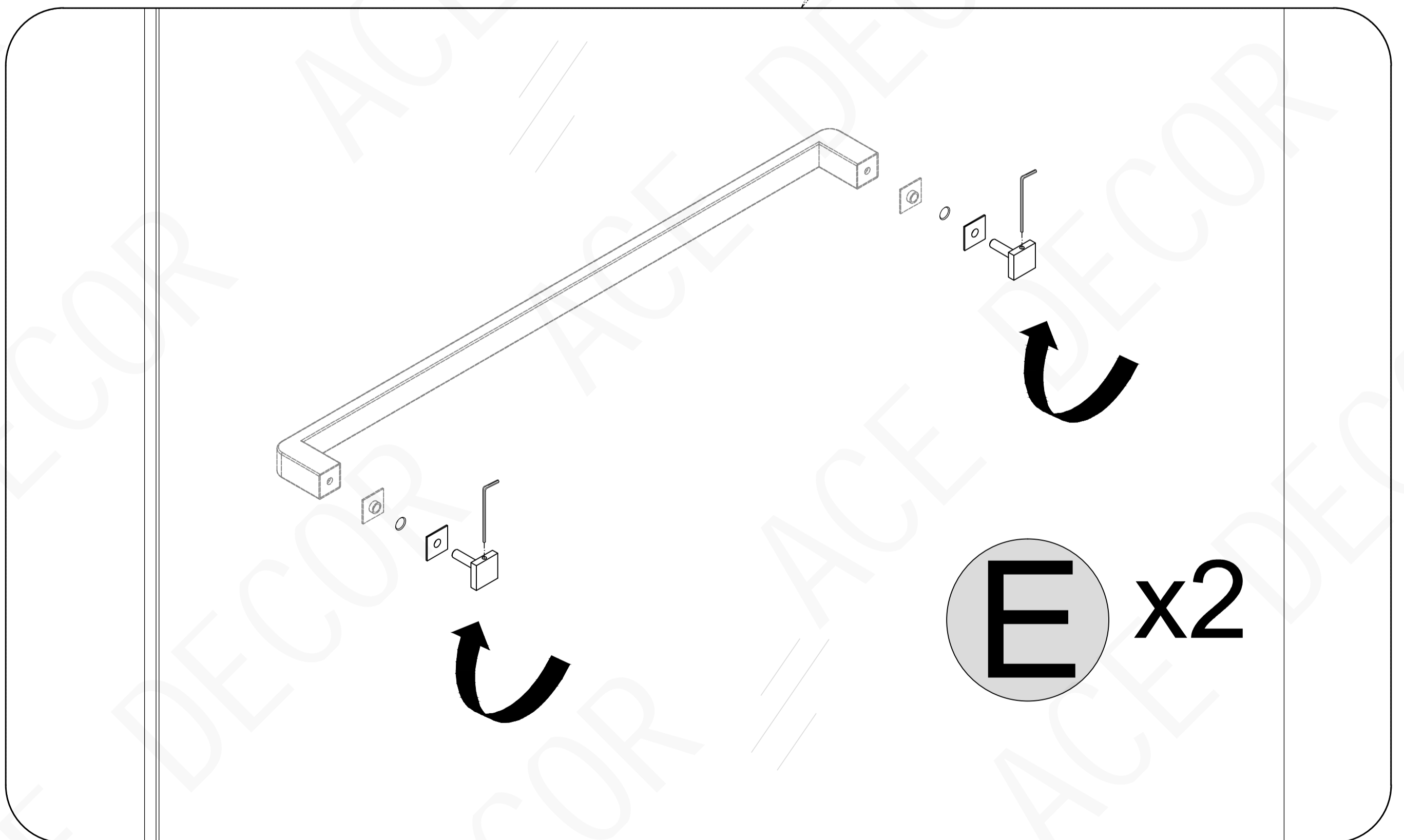
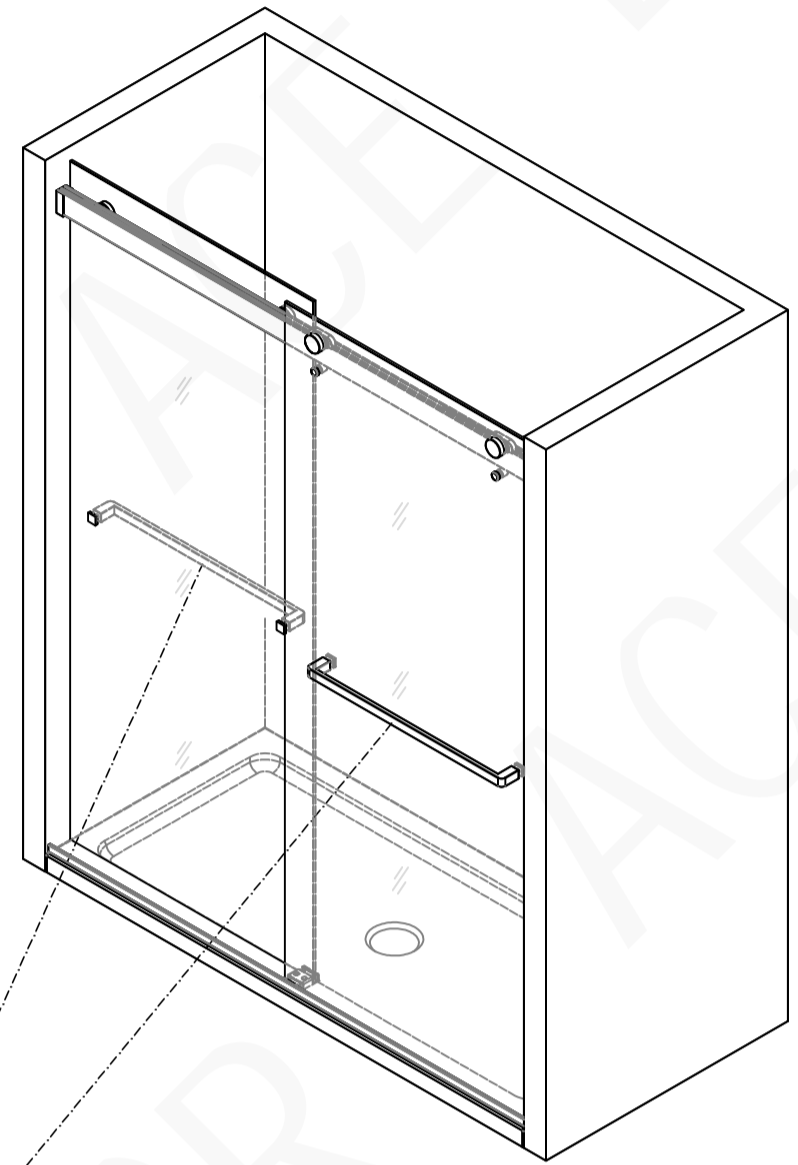

10 Attach the Anti-collision rubber strip (D) to Door panel

NOTE

2 pieces on the each door.

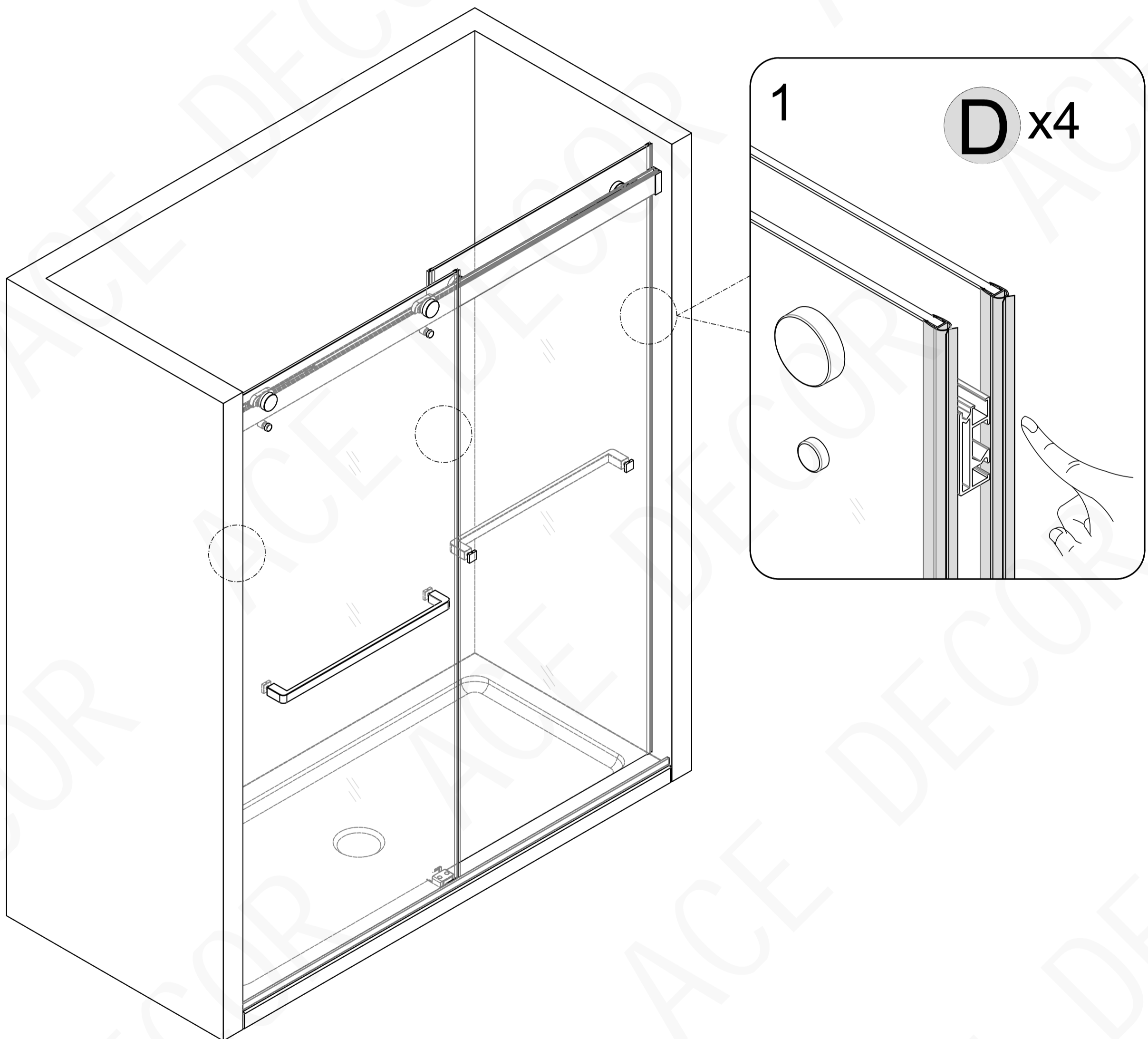

11 SEALING

- ⚠ The surfaces need to be clean and free of debris before applying silicone.

Ensure that the Shower door closes tightly and opens smoothly.

Apply a good quality silicone sealant along the Bottom Rail (A) .

- ⚠ **Allow 24 hours for the silicone to cure before using the shower.**

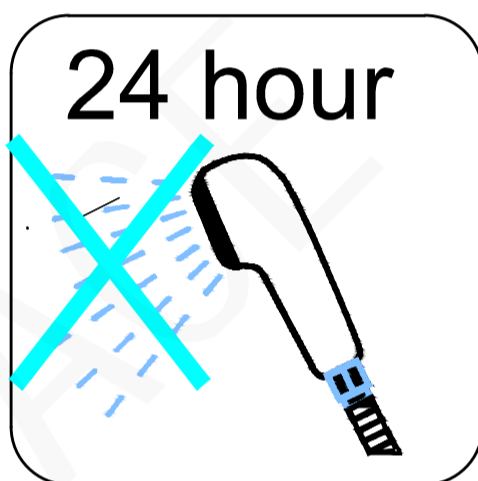

! Apply Silicone Sealant, (not supplied).

Inside View

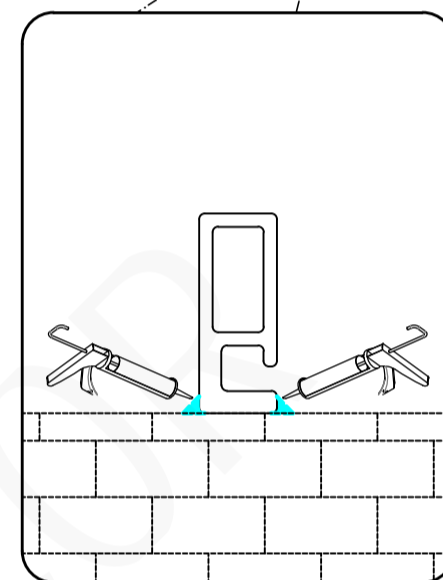
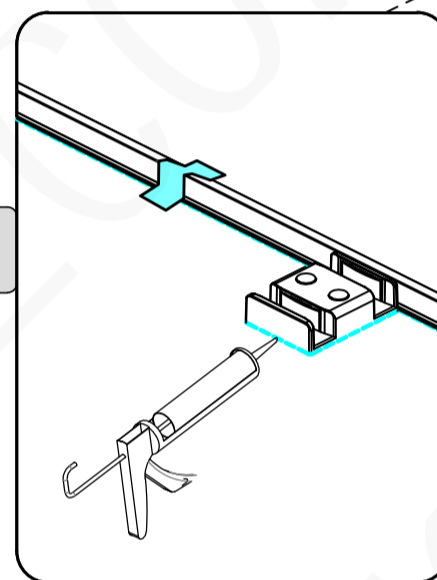

Apply silicone around the bottom rail.



Use Painter's Tape to hold the Water seal tight in position while the silicone cures.

11 Complete.

Install the shower head on the door's side as shown in the illustration! This will reduce the risk of leaking.

