



JP0206

FEATURE HIGHLIGHTS

- ☞ Double sliding (bypass) design for easy access from either side
- ☞ Can be trimmed up to 4" for width adjustment
- ☞ Dual towel bar on each panel

SPECIFICATIONS

Dimension(1524mm W x 1930mm H)

- ☞ Fits 56" to 60" finished opening
- ☞ Up to 4" (102mm) in width adjustment
- ☞ Custom made is available

Glass

- ☞ 3/8" (10mm) or 5/16" (8mm) thick tempered glass
- ☞ ANSI certified tempered glass

Hardware

- ☞ Aluminum sliding track and wall profile
- ☞ S.S. durable rollers
- ☞ Slim aluminum bottom threshold designed to prevent water leakage
- ☞ #304 stainless steel towel bar style handle
- ☞ Hardware finished in Chrome, Brushed, Black



Chrome



Brushed



Black

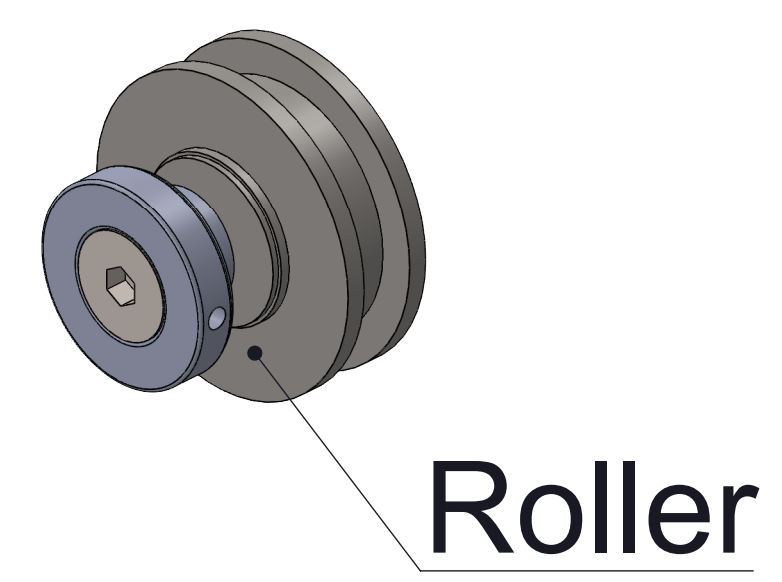

Roller

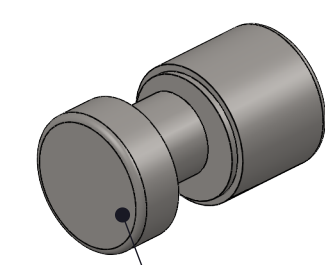

Anti bouncer

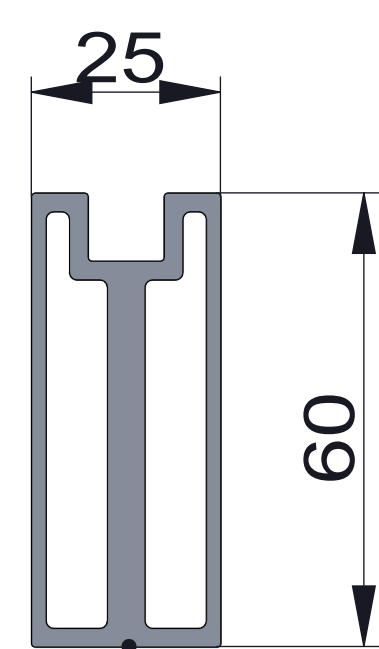

Top rail

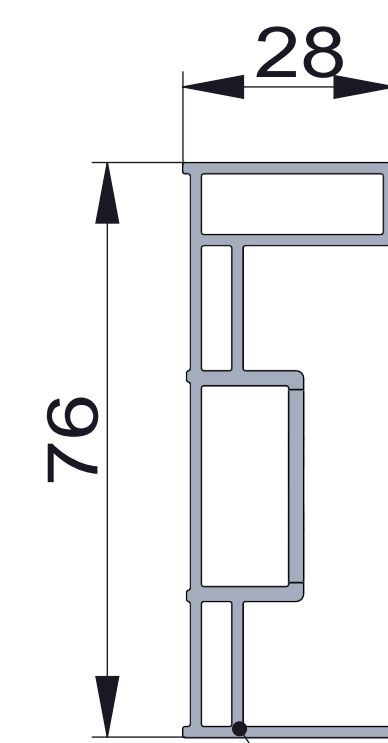

Wall channel

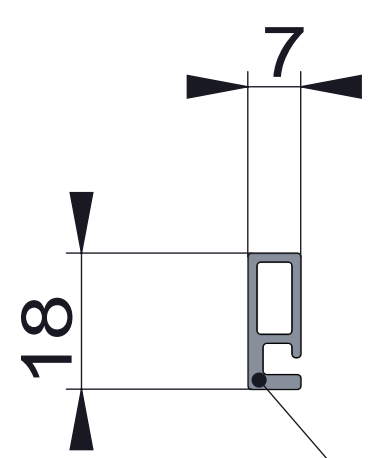

Water bar

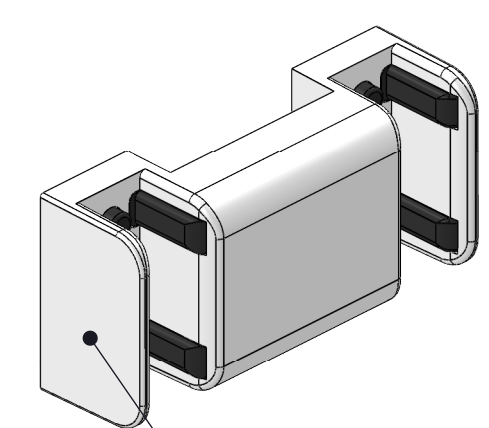

Bumper



Handle

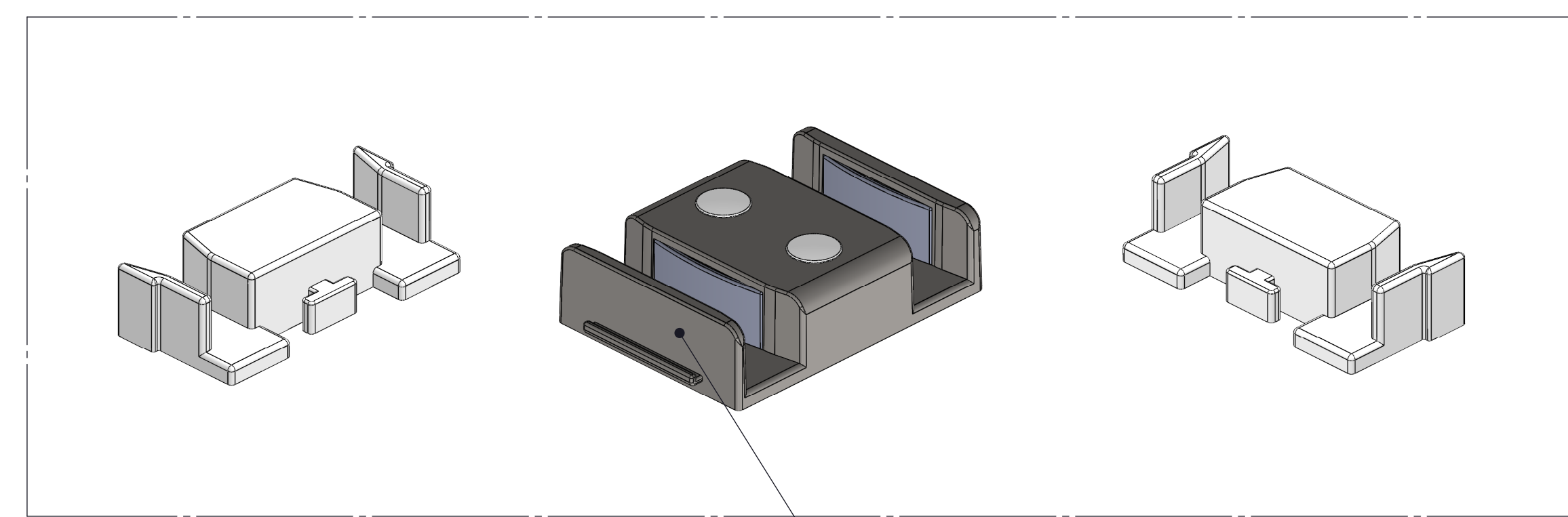

Bottom guide

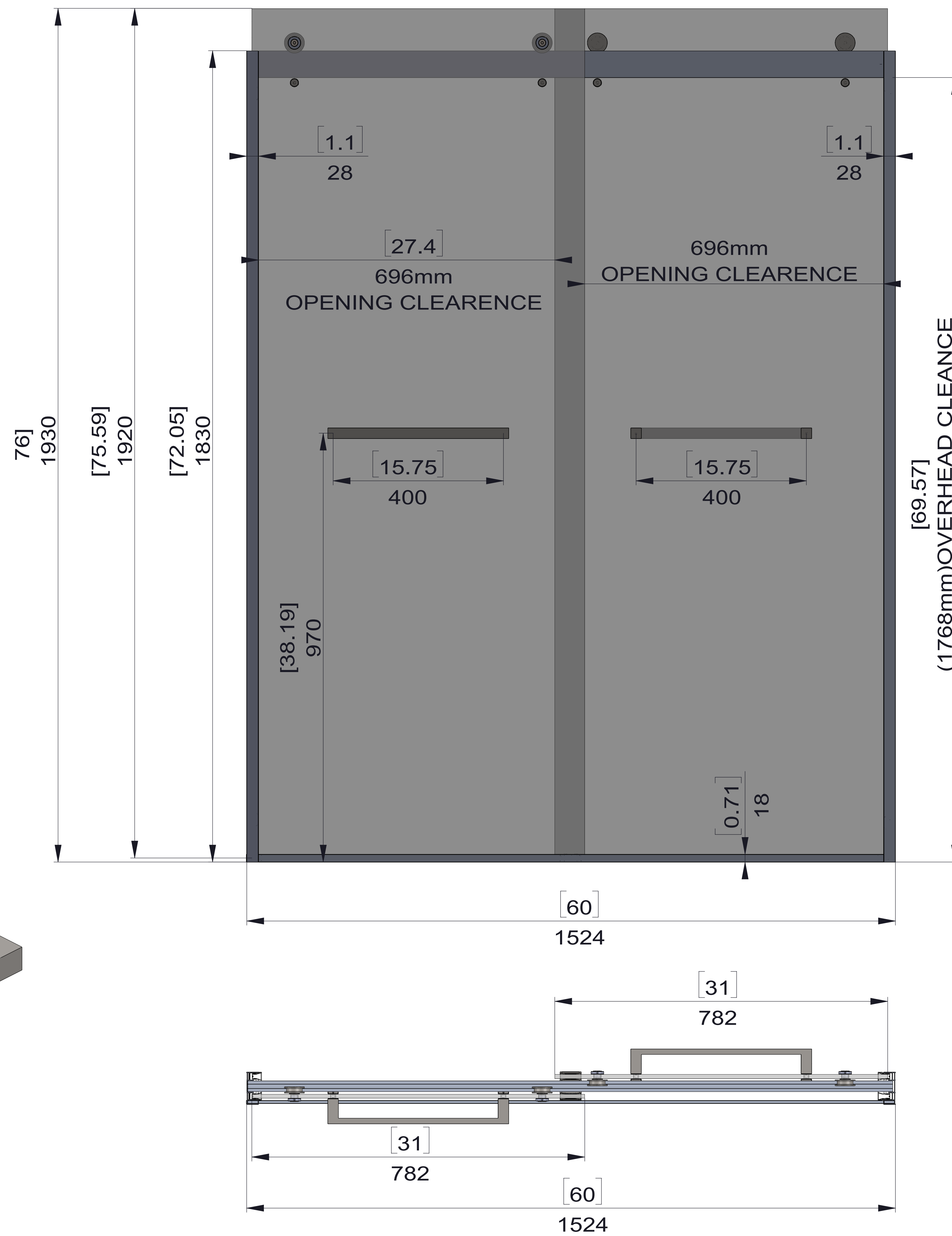

Glass 10mm