



JK1712

FEATURE HIGHLIGHTS

- ☞ Double sliding (bypass) design for easy access from either side
- ☞ Can be trimmed up to 4" for width adjustment
- ☞ Dual towel bars double as handles on each panel

SPECIFICATIONS

Dimension(60 in. W x 76 in. H)

- ☞ Fits 56" to 60" finished opening
- ☞ Up to 4" (102mm) in width adjustment
- ☞ Custom made is available

Glass

- ☞ 3/8 in. (10mm) thick or 5/16 in.(8mm) tempered glass
- ☞ ANSI certified tempered glass

Hardware

- ☞ Aluminum sliding track and wall profile
- ☞ ABS+POM+S.S. durable wheel
- ☞ Slim aluminum bottom threshold designed to prevent water leakage
- ☞ #304 stainless steel towel bar style handle
- ☞ Hardware finished in Chrome, Brushed, Black



Chrome



Brushed



Black

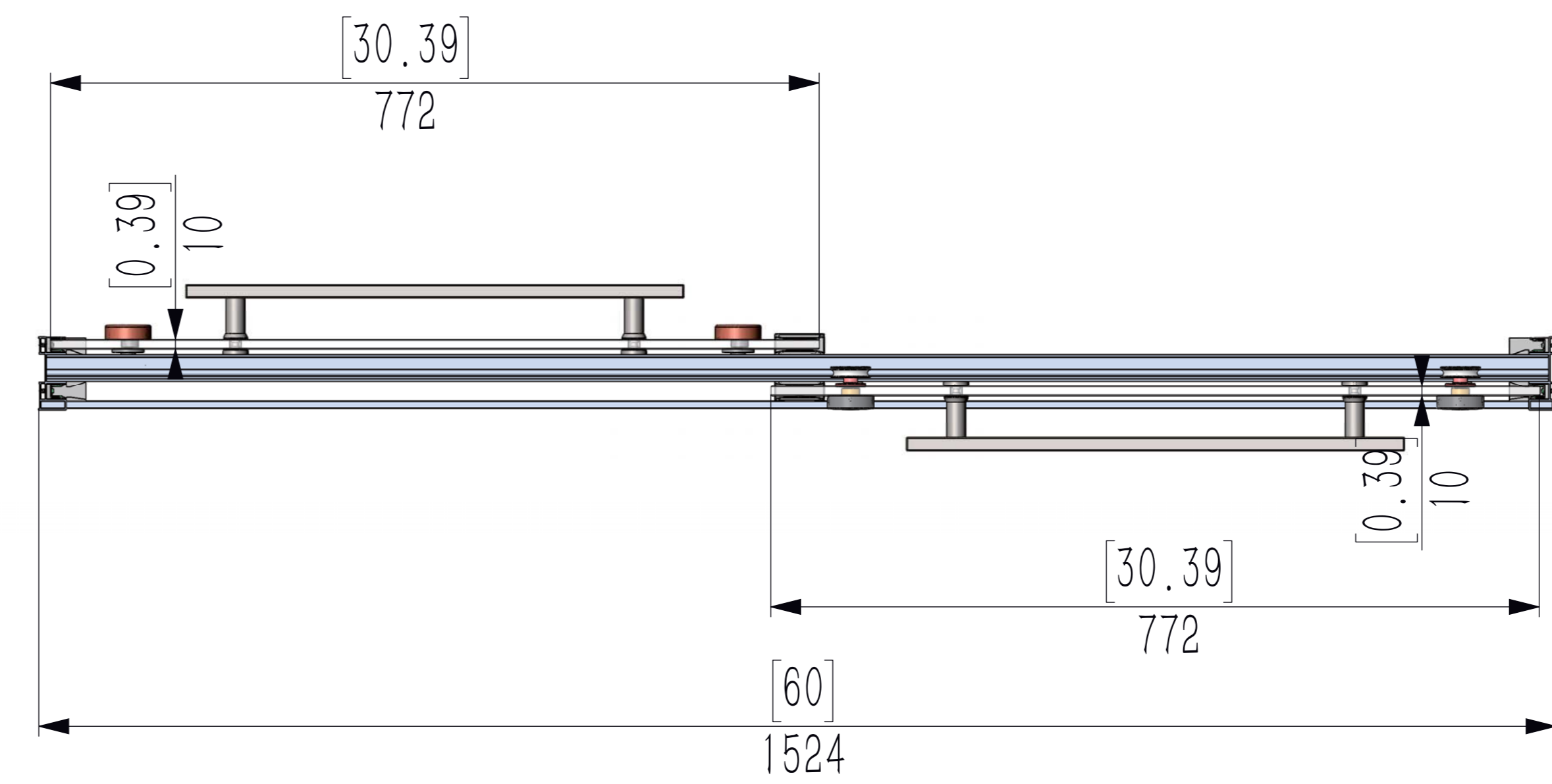
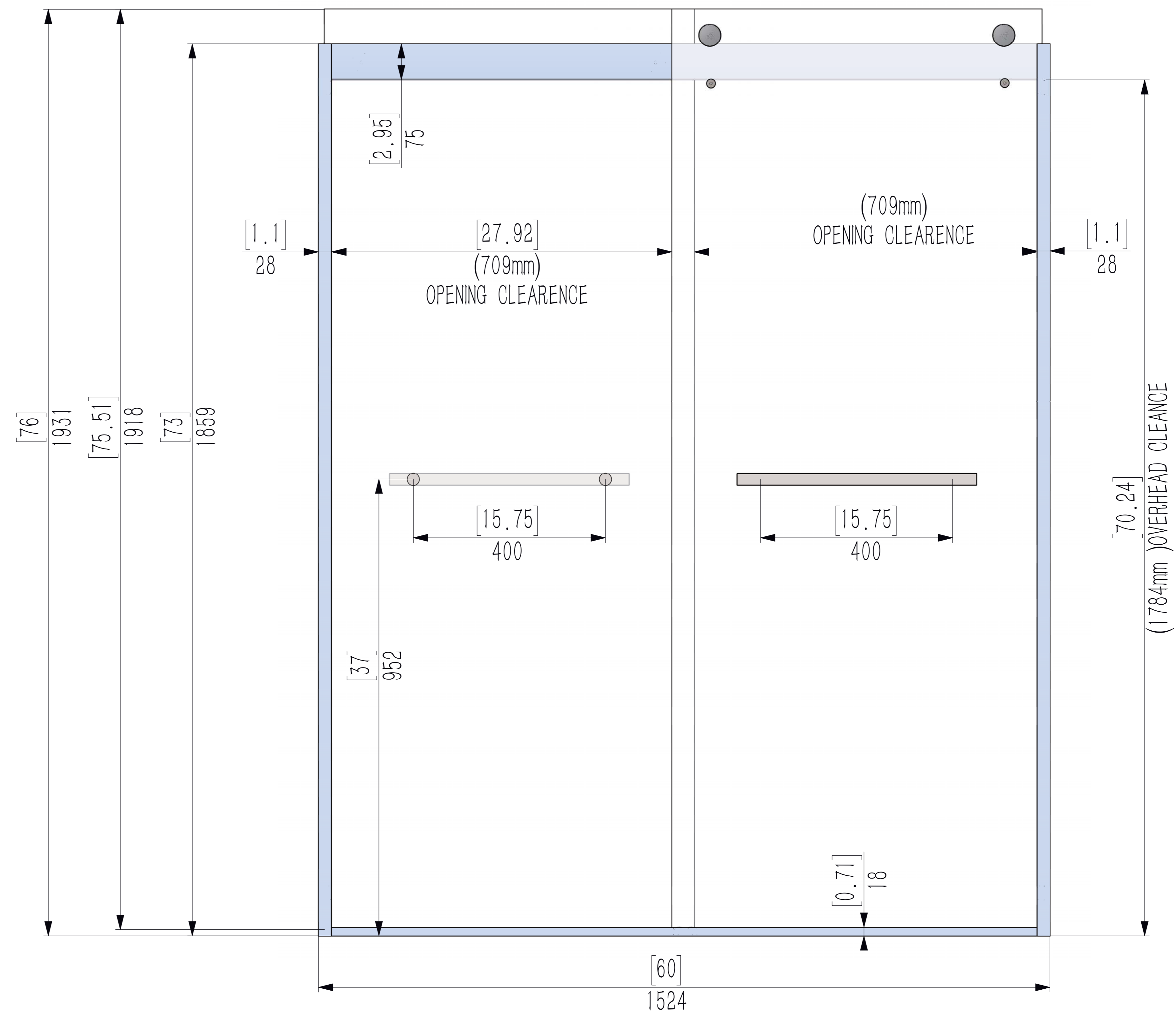
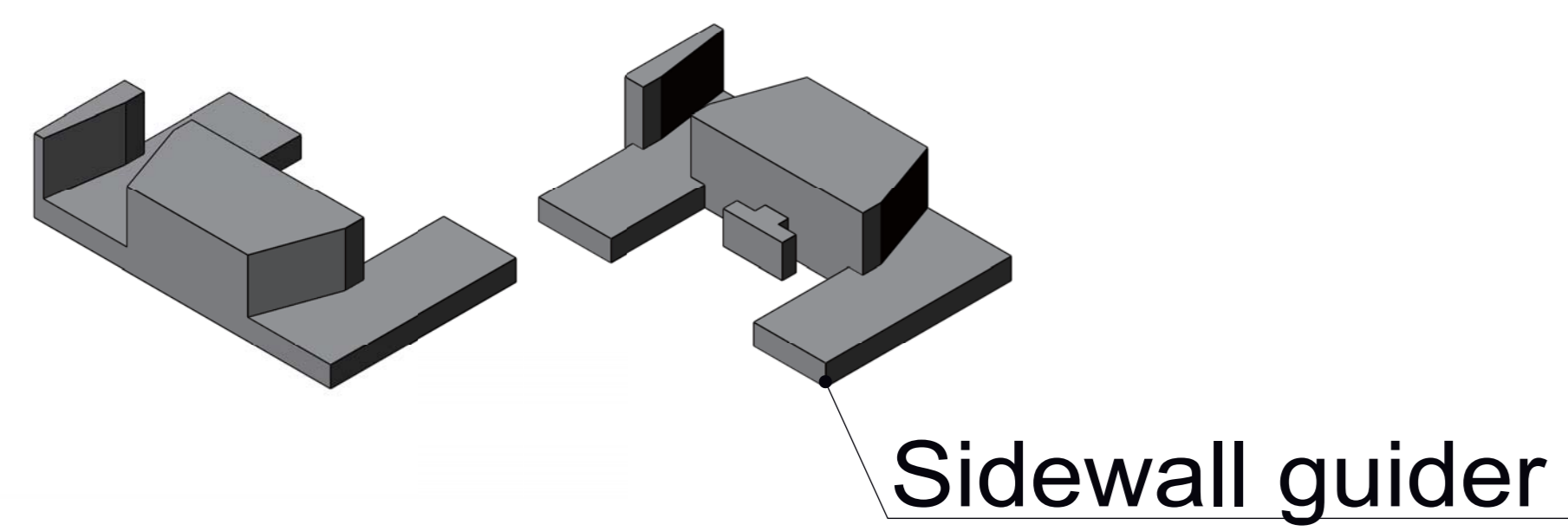
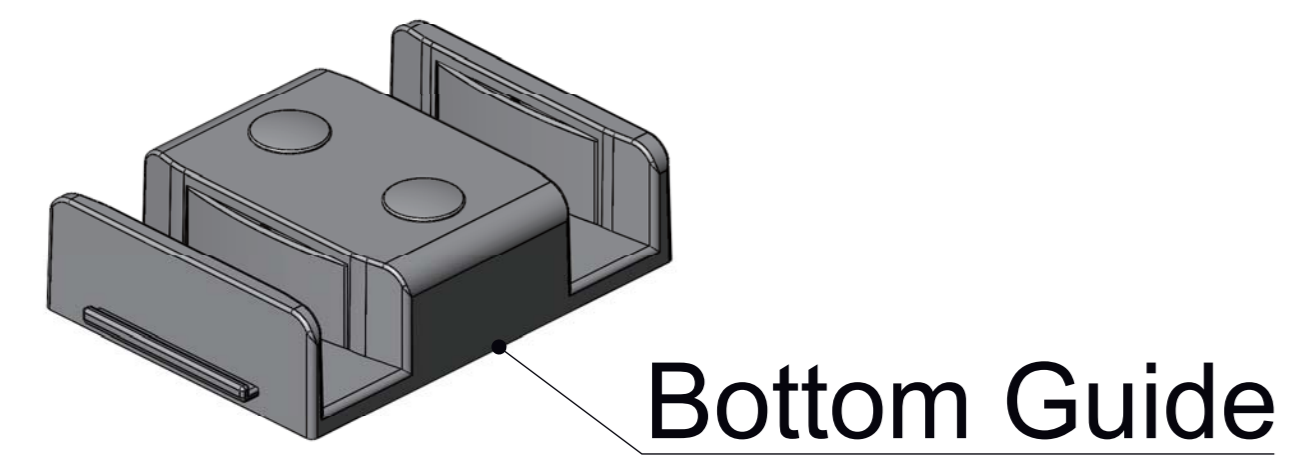
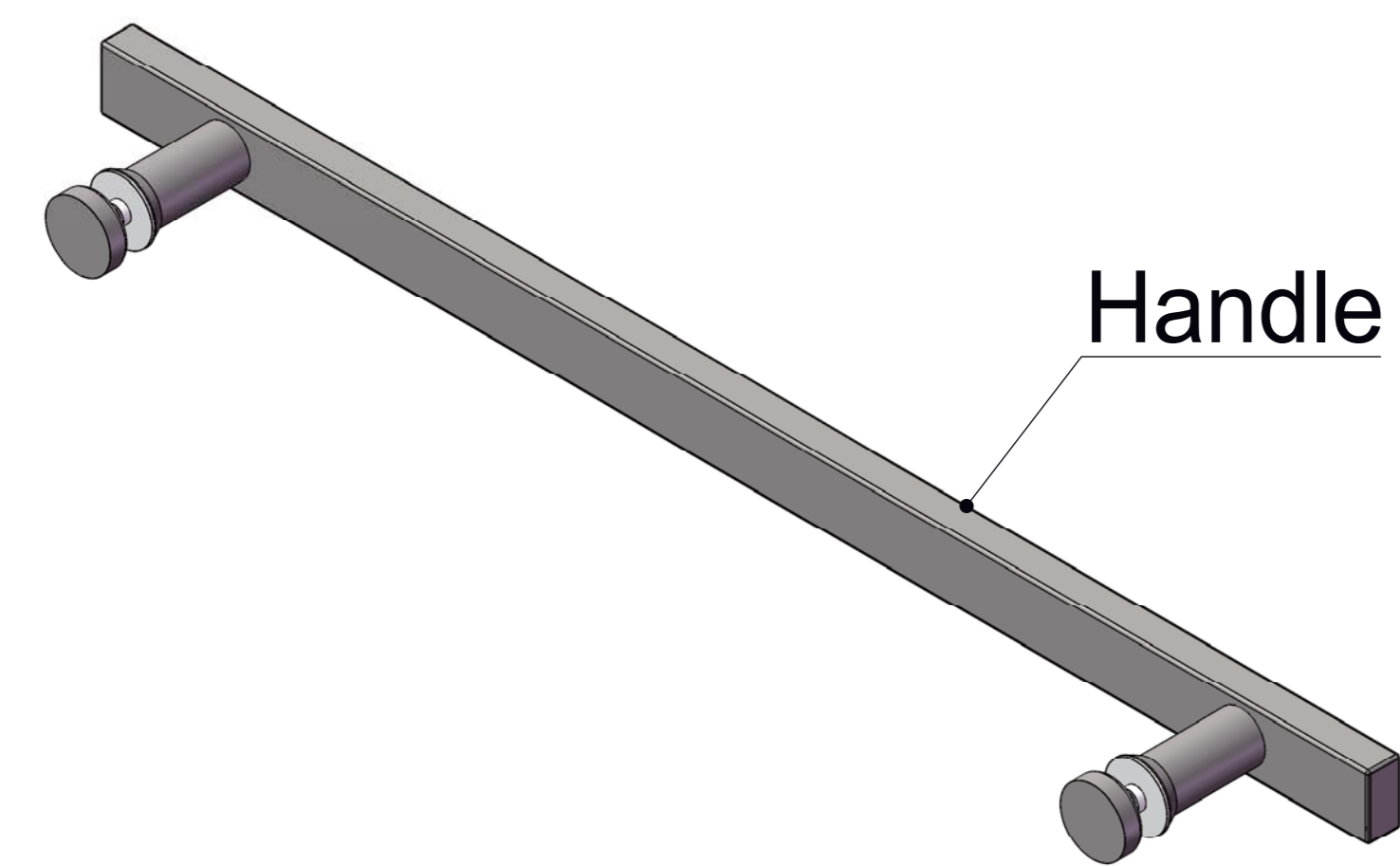
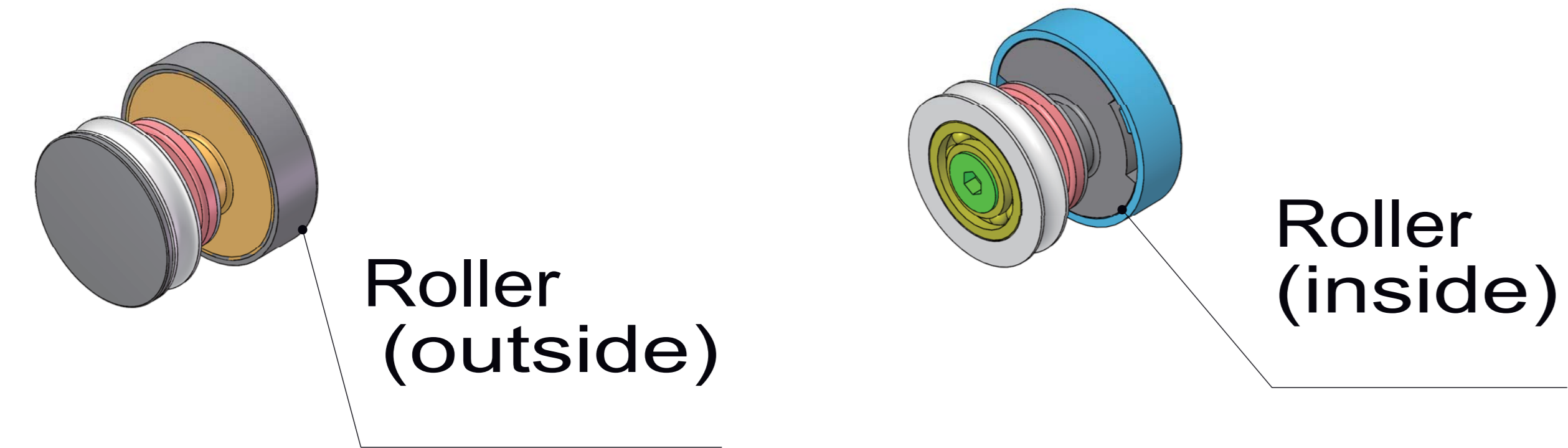
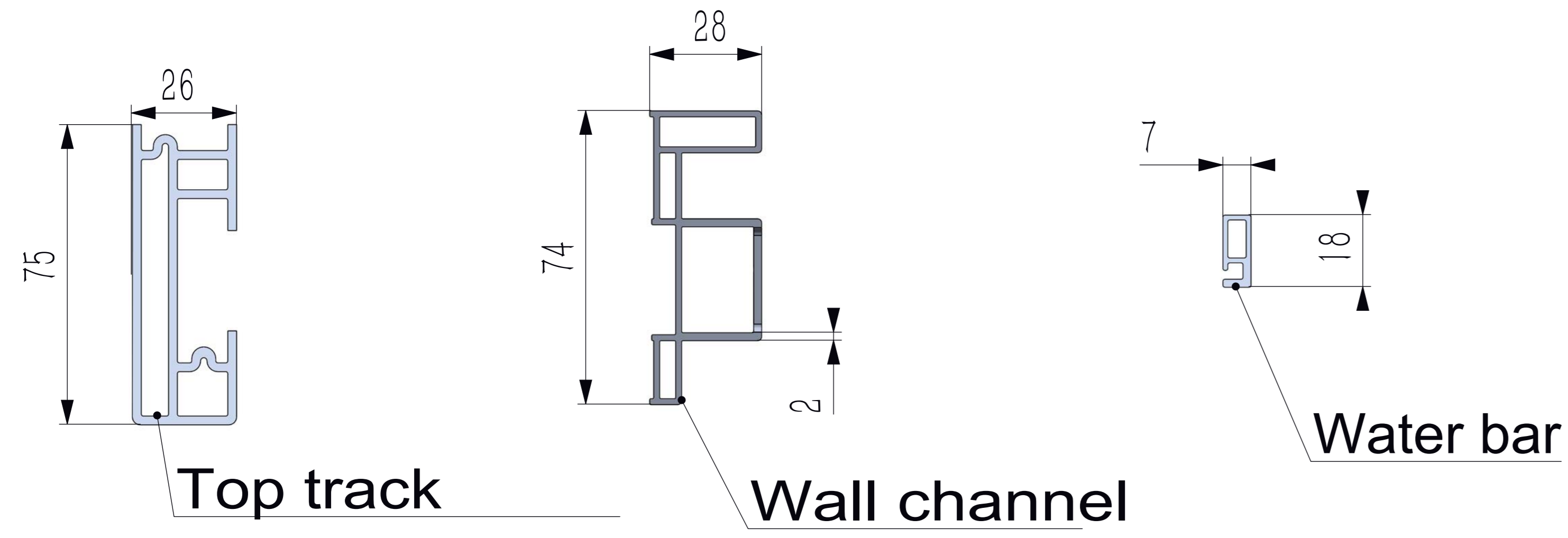

Glass 10mm or 8mm

